

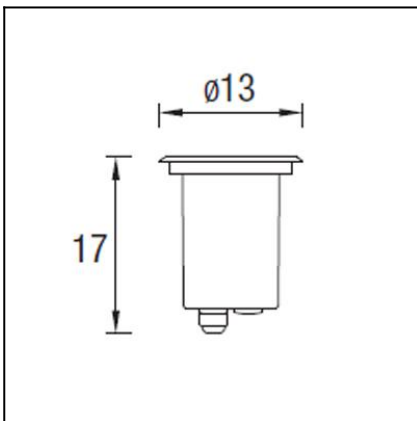

The photograph may not match the reference exactly. Please read the product description to identify the finish.



DESCRIPTION

May be flush mounted into the ground. Body produced in techno-polymer with a tempered glass diffuser. Available with an AISI 304 or AISI 316 stainless steel surround. For GU-10 light source, compatible with LED, compact fluorescent and halogen lamps. Can be rotated by $\pm 15^\circ$. Its wire outlets on both sides makes it suitable for an array installation. Includes flush mounting box.

TECHNICAL CHARACTERISTICS

Type:	Uplight
Adjustable $\pm 15^\circ$ on the vertical axis	
IP Protection degrees:	IP67
IK Protection degrees:	IK08
Lampholder:	1 x GU10
Power (W):	GU10 MAX 50W
Total power consumption (W):	50
Voltage / Frequency:	230V/50-60Hz
Units per box:	4
Net Weight (Kg):	0.775
EAN:	8435111069707



MATERIALS / FINISHES

Structure material: Stainless steel AISI304
Technopolymer

Diffuser material: Glass

Diffuser finish: Tempered

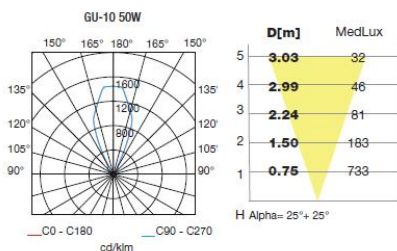

Download photometric file .ldt / .ies

71-9448-CA-CA



Structure material: Stainless steel AISI316

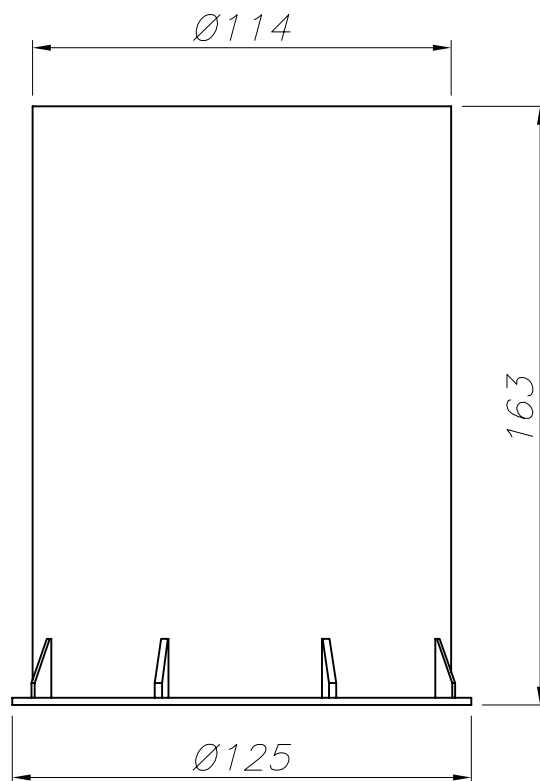
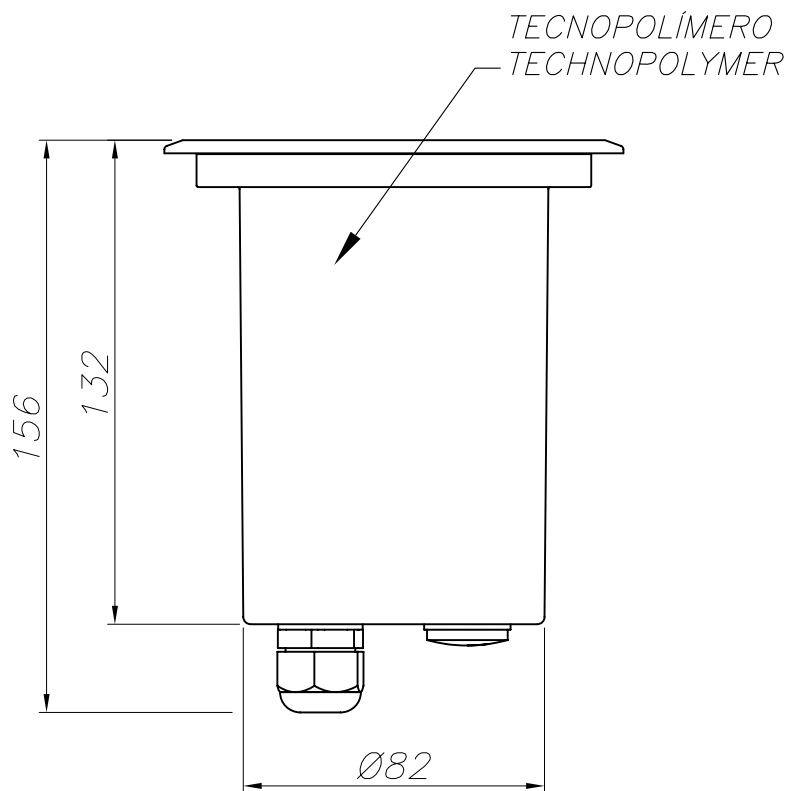

CAJA DE EMPOTRAR
FLUSH FITTING BOX

