

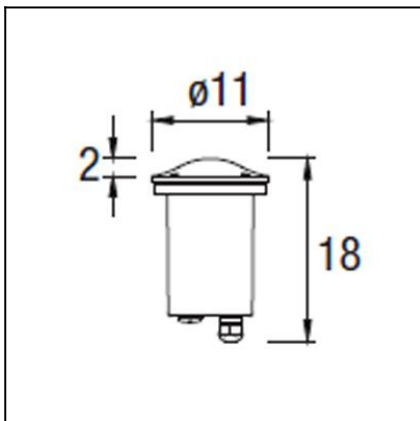

The photograph may not match the reference exactly. Please read the product description to identify the finish.



DESCRIPTION

May be flush mounted into the floor. Techno-polymer body and clear polycarbonate diffuser. Includes anti-light pollution reflector. Available in 11cm diameter for GU11 and in 18 cm diameter for E-27. Compatible with LED and compact fluorescent lights (not supplied). Its wire outlets on both sides makes it suitable for an array installation. Includes flush mounting box.

TECHNICAL CHARACTERISTICS

Type:	Uplight
IP Protection degrees:	IP67
IK Protection degrees:	IK10
Lampholder:	1 x GU10
Power (W):	GU10 MAX 14W
Total power consumption (W):	14
Voltage / Frequency:	230V/50-60Hz
Units per box:	8
Net Weight (Kg):	0.59
EAN:	8435111075173

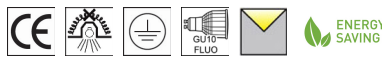

MATERIALS / FINISHES

Structure material:	Technopolymer Fiber glass	Diffuser material:	Polycarbonate
		Diffuser finish:	Transparent

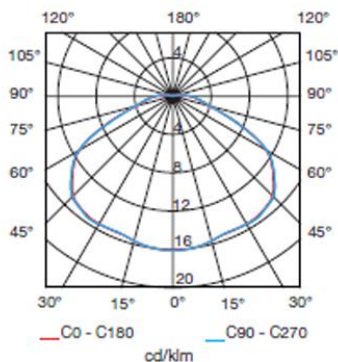

Download photometric file .ldt / .ies

Luminaire		Measurement		Lamp	
Code	55-9421-M3-M3	Code	55-9421-M3-M3	Code	LAMPARA 7W GU10
Name	Uplight XENA 7W GU10	Name	Uplight XENA 11W fluor GU10	Number	1
Line	- LEDS C4 LEDS	Date	24-12-2010	Position	Universal
Efficiency	96.25%	Coordinate system	C-G	Total Flux	66.00 lm
Maximum value	16.12 cd	Position	C=0.00 G=0.00	Double Symmetrical	

Diam=106mm

C Halfplanes

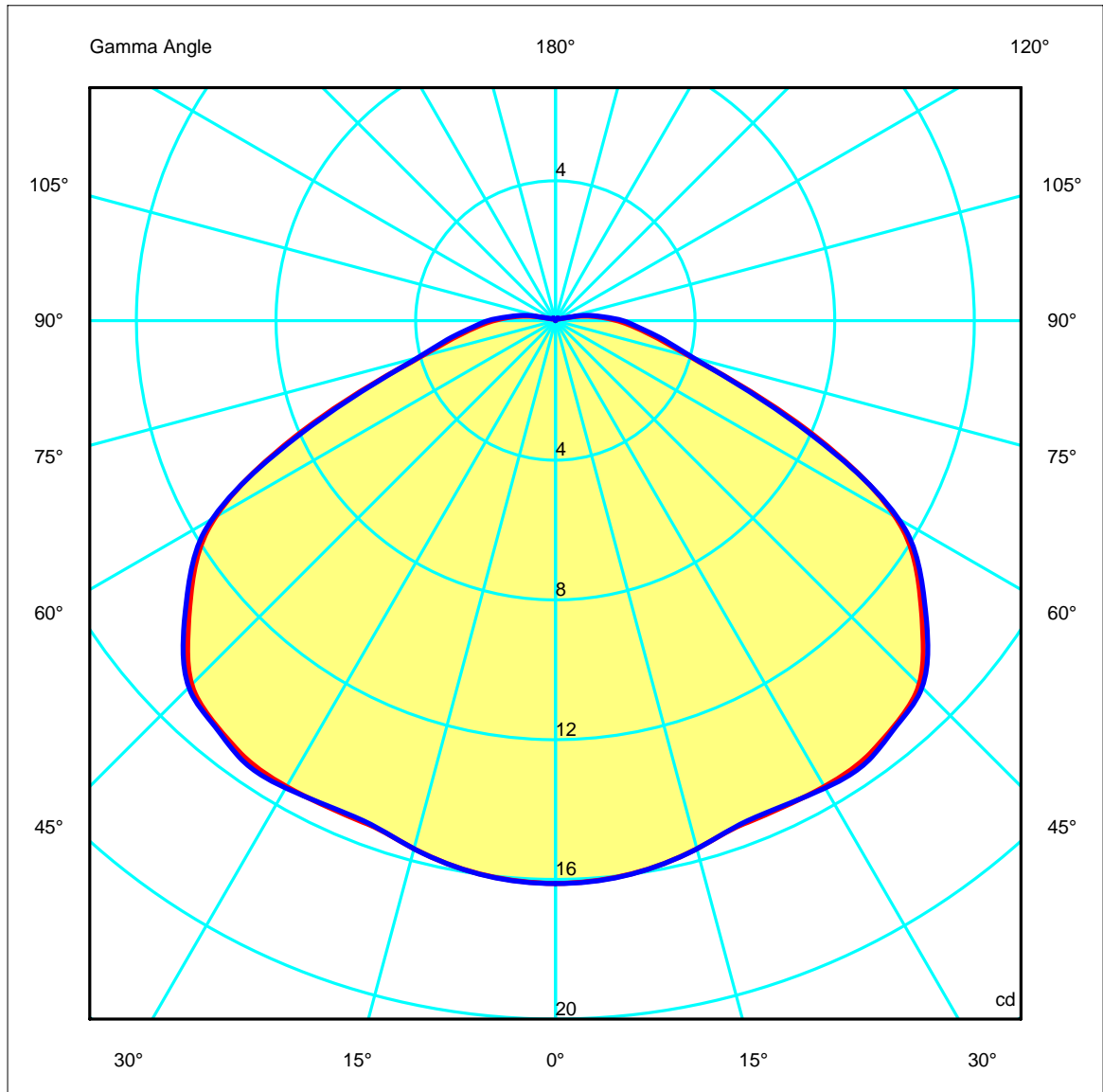
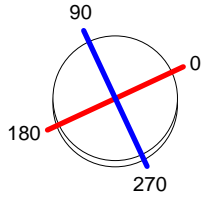

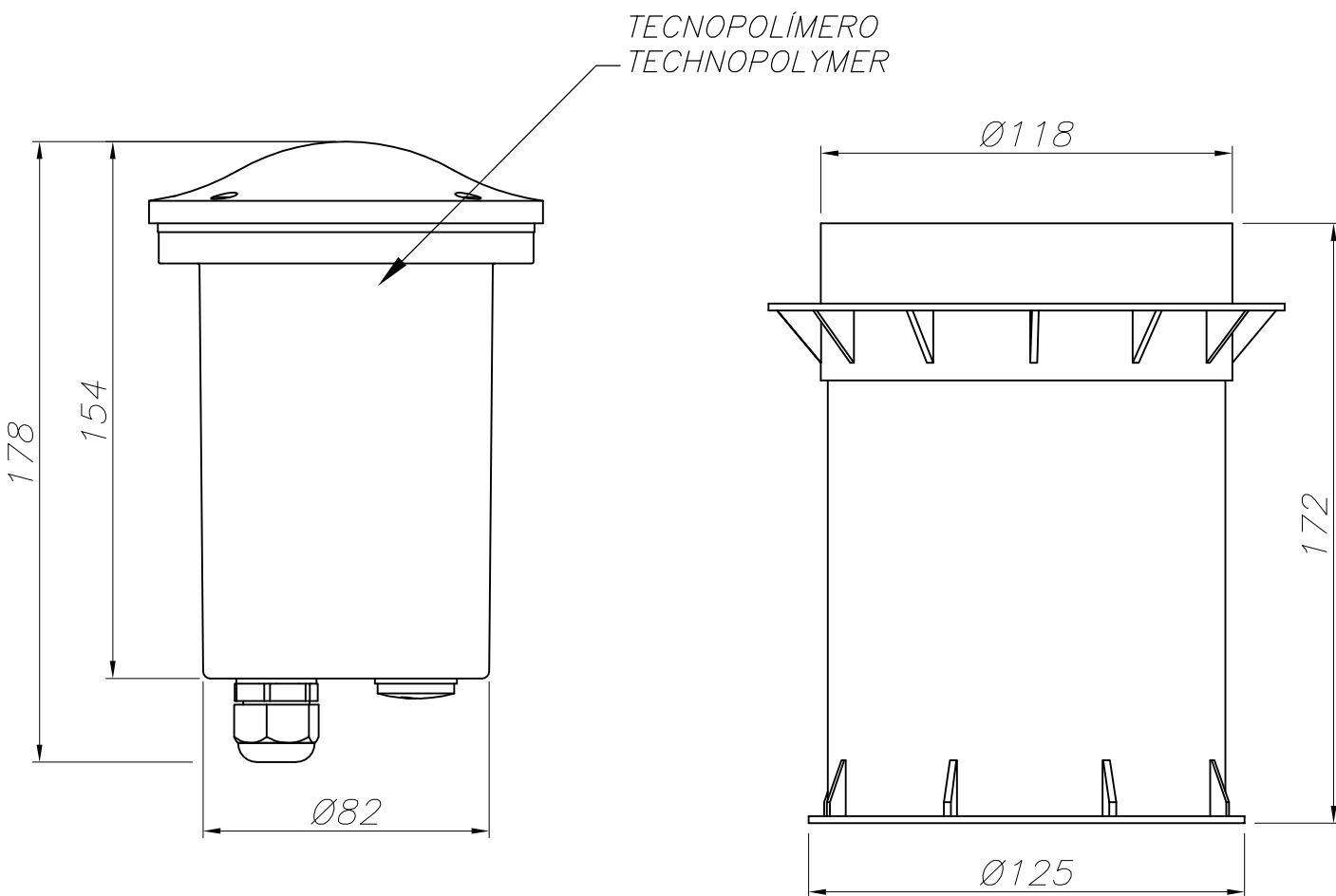

CAJA DE EMPOTRAR
FLUSH FITTING BOX

