

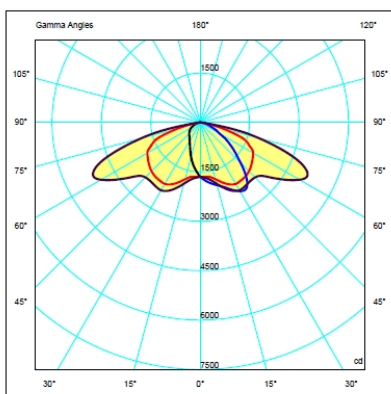

The photograph may not match the reference exactly. Please read the product description to identify the finish.

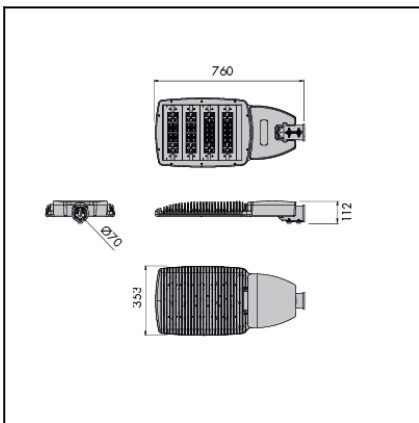

[Download photometric file .ldt / .ies](#)

DESCRIPTION

LED luminaire for street lighting. TOP and SIDE fitting of Ø60mm via the incorporated accessory. Available in versions for different power ratings (80W, 100W and 130W). IP 66 for the optical group. 129 lm/W efficiency for LEDs at 700mA and Tj of 85°C. Vossloh driver for voltages of 220-240V, 50-60Hz and 700 mA for the LEDs.

TECHNICAL CHARACTERISTICS

Type:	Streetlight head
Adjustable $\pm 15^\circ$ on the horizontal axis.	
IP Protection degrees:	IP65
IK Protection degrees:	IK08
Bulb:	64 x LED Osram. Neutral white - 4000K
Power (W):	130
Total power consumption (W):	151.7
Luminous efficacy (Lm/W):	129
CRI:	72
Voltage / Frequency:	120-277V/50-60Hz
Warranty (Years):	2
Option to extend the guarantee:	Yes, 5 years
Units per box:	1
Net Weight (Kg):	6.19
EAN:	8,43538E+12
ULOR (%):	0.74

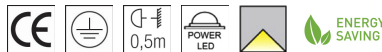

MATERIALS / FINISHES

Structure material:	Injected aluminium	Diffuser material:	Tempered glass
Structure finish:	Pearl grey	Diffuser finish:	Transparent

GEAR

Multi-voltage electronic gear included (120-277V / 50-60Hz)

Luminaire		Measur.		Lamp		
Code	80-1781	Code	80-1780	Code	LEDS 80-1780	
Name	Cabezal leds ESSENCIAL HP 130W	Name	Cabezal leds ESSENCIAL HP 130W	Number	1	
Line	- LEDS C4	Date	08-02-2013	Position	Universal	
Efficiency	82.38%	Coordinate system	CG Roads	Total Flux	13787.40 lm	
Maximum value	5889.26 cd	Position	C=20.00 G=62.50	Sym. on planes	270-90	
Rectangular Luminaire	Length	760 mm	Width	350 mm	Height	90 mm
Rectangular Luminous Area	Length	380 mm	Width	245 mm	Height	0 mm
Horizontal Luminous Area	0.093100 m2	Emitting area on Plane 180°	0.000000 m2			
Emitting area on Plane 0°	0.000000 m2	Emitting area on Plane 270°	0.000000 m2			
Emitting area on Plane 90°	0.000000 m2	Glare area at 76°	0.022523 m2			
Symmetry Type	Sym. on planes 270-90	Maximum Gamma Angle	180			
Measurement Distance	6.44	Measurement Flux	13787.00 lm			
Operator	Asselum T2	Source voltage	230.00 V			
Temperature	20.00 °C	Source current	PRC			
Humidity	39.00 %	Photocell				
Notes						

Luminaire Lamps					
Line	Code	Name	Flux [lm]	Pow. [W]	Q.ty
- LEDS C4 LEDS	LEDS 80-1780	Lampara led blanco 130W	13787.40	130.00	1
C.I.E.	39 72 95 99 82	D DIN 5040	A21		

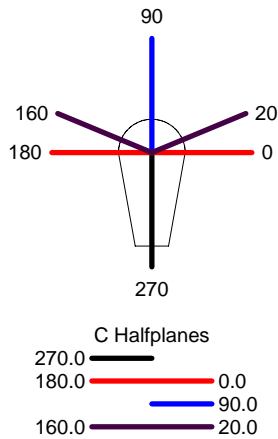

ULOR 0.62 %
 DLOR 81.77 %
 RN 0.75 %

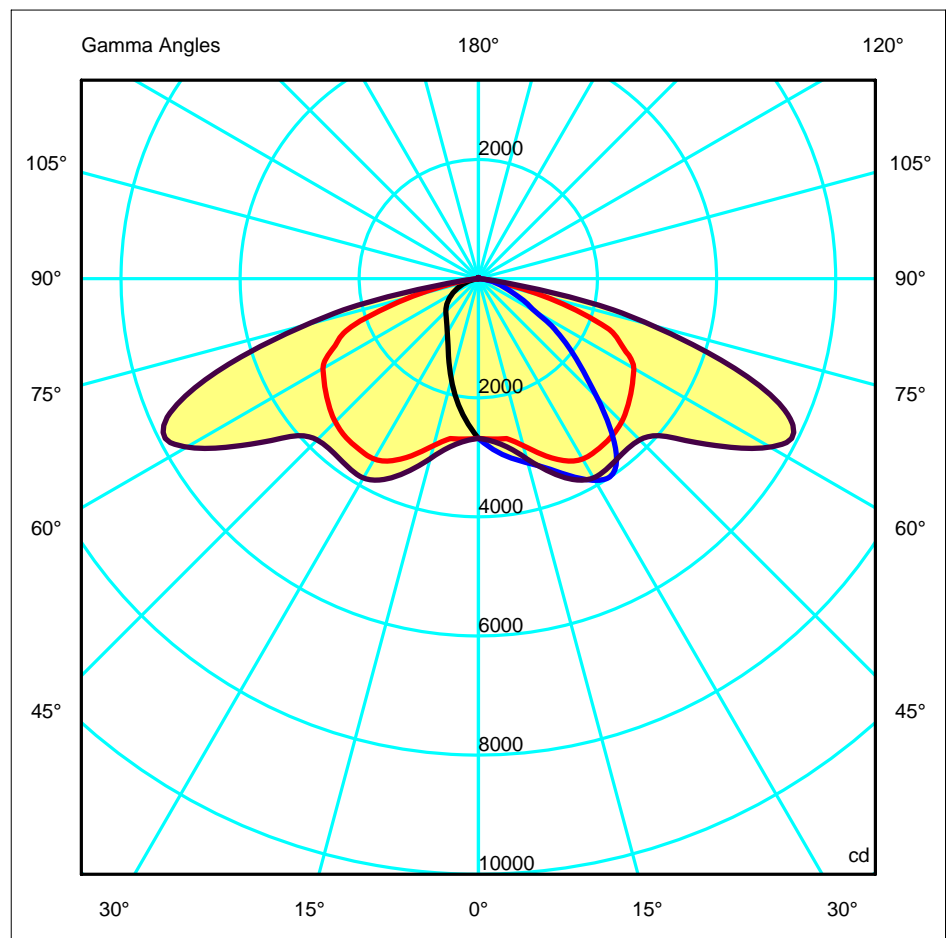

TEMPERED GLASS / VIDRE TEMPLAT

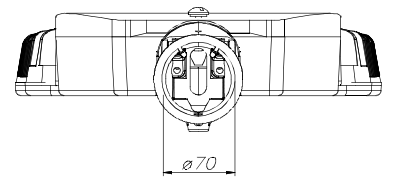
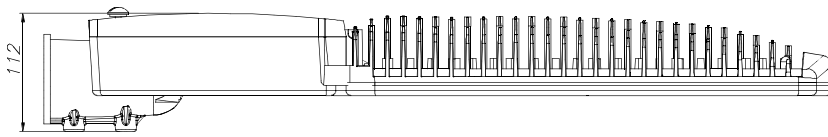
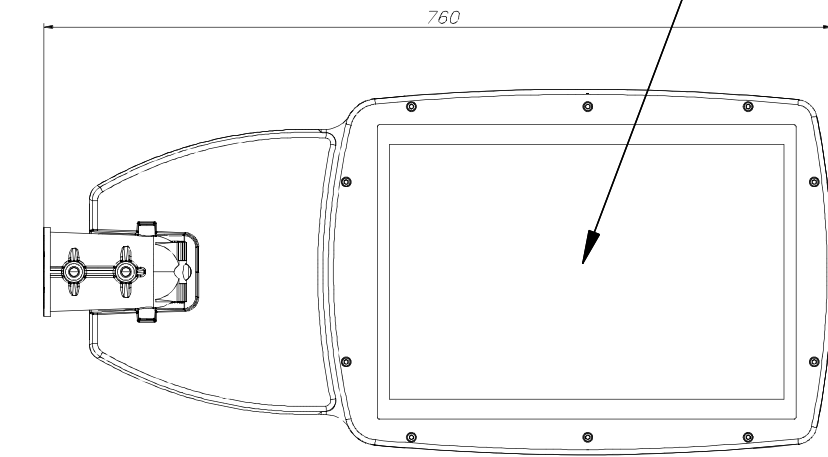

INJECTED ALUMINIUM / ALUMINI INJECTAT

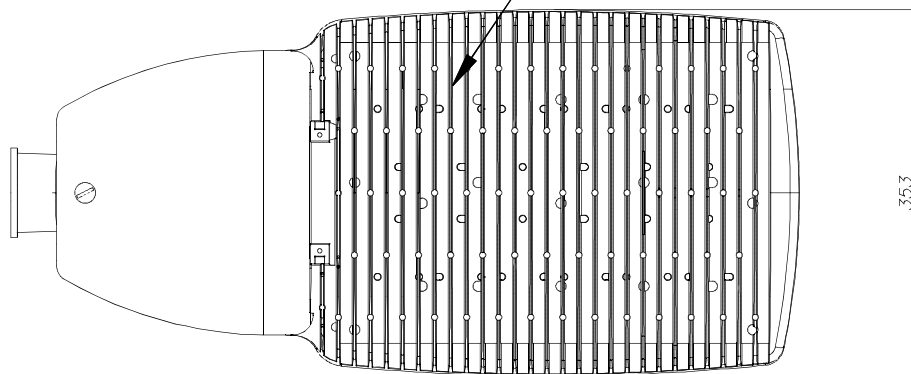

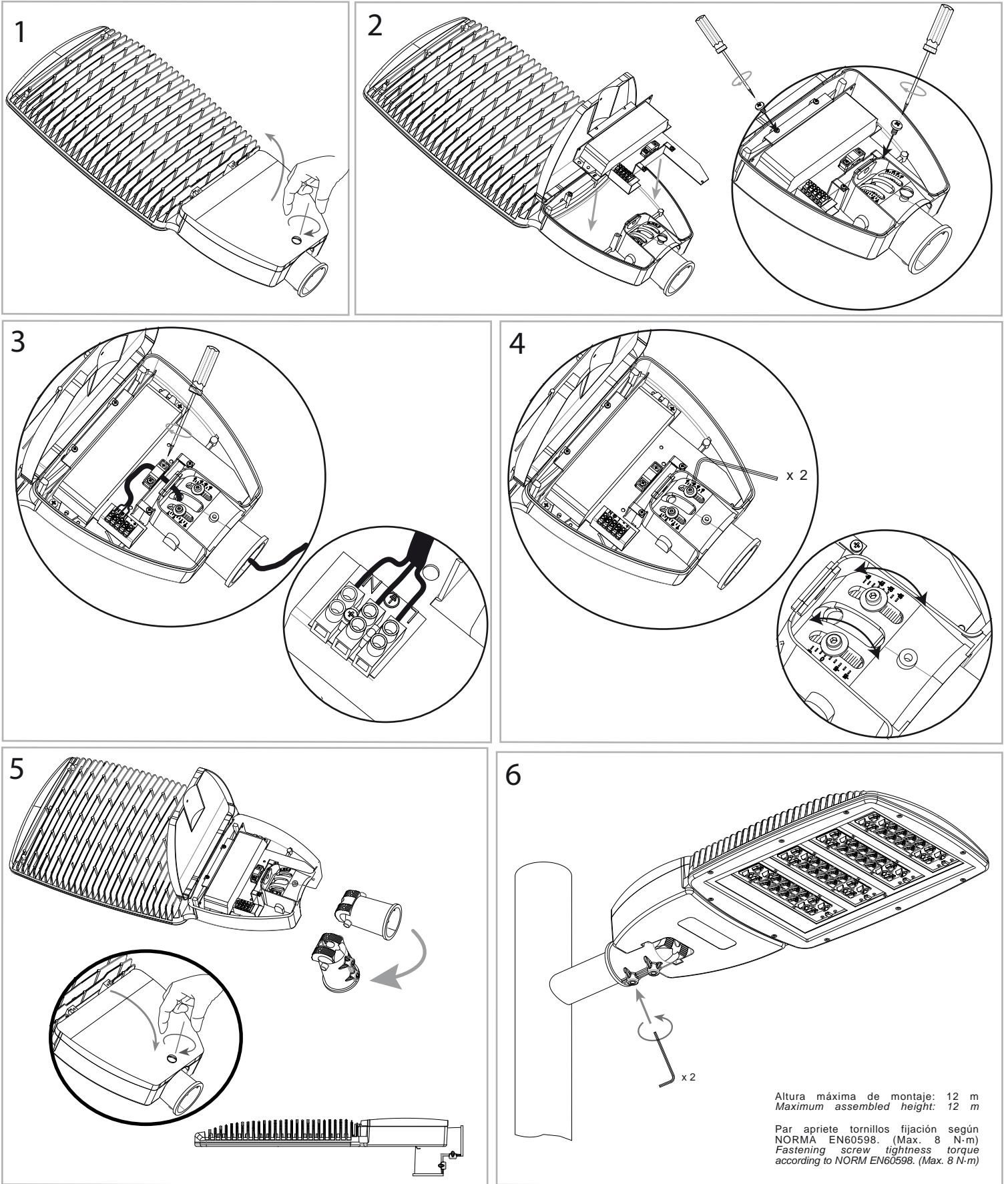

CONEXIONES ELECTRICAS / ELECTRICALS CONNECTIONS

REGIMEN NORMAL /
NORMAL RATED POWER

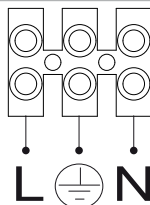

POT W	DESCRIPCIÓN/ DESCRIPTION	CÓDIGO/ CODE	Voltaje (V) / Voltage (V)	EQUIPO ELECTRÓNICO/ GEAR
80 W	RÉGIMEN NORMAL / NORMAL RATED POWER	80-1767-AT-37	220-240V	VOSSLOH DRIVER
	RÉGIMEN NORMAL / NORMAL RATED POWER	80-1768-AT-37	120-227V	PHILIPS DRIVER
100 W	RÉGIMEN NORMAL / NORMAL RATED POWER	80-1769-AT-37	220-240V	VOSSLOH DRIVER
	RÉGIMEN NORMAL / NORMAL RATED POWER	80-1779-AT-37	120-227V	PHILIPS DRIVER
130 W	RÉGIMEN NORMAL / NORMAL RATED POWER	80-1780-AT-37	220-240V	VOSSLOH DRIVER
	RÉGIMEN NORMAL / NORMAL RATED POWER	80-1781-AT-37	120-227V	PHILIPS DRIVER

220-240V
50-60Hz
VOSSLOH

120-277V
50-60Hz
PHILIPS

80
Lm/watt
luminaria
luminaire

Neutral W
4000K

>50.000 h

40
LEDS
80W

48
LEDS
100W

64
LEDS
130W



VOSSLOH
PHILIPS

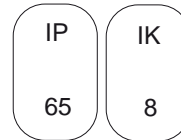
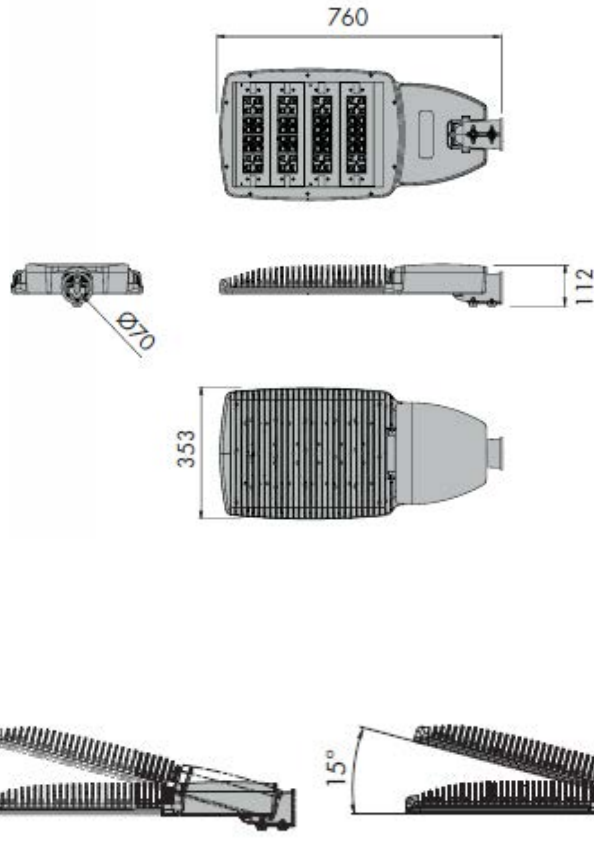

- Todos los productos están fabricados siguiendo las normas de seguridad y electromagnetismo de Europa: EN 60598-1:2004, EN 60598-2-3:2003, EN 55015:2006, EN 61000-3-2:2006, EN61000-3-3:1995, EN 61547 y marcado CE.
- All products are manufactured according to the European safety norms and electromagnetic standards: EN 60598-1:2004, EN 60598-2-3:2003, EN 55015:2006, EN 61000-3-2:2006, EN61000-3-3:1995, EN 61547 and CE mark.

DERECHOS DE GARANTÍA

El fabricante LEDS-C4, S.A. garantiza el correcto funcionamiento del equipo y posibles reparaciones o suministro de recambios del modelo debidos a defectos de fabricación durante 2 años desde la fecha de entrega, pero no puede responsabilizarse de daños y/o perjuicios causados por un mal empleo del mismo. Para cualquier reclamación, se deberá adjuntar a esta garantía el ticket de compra. La empresa se compromete a la reparación total gratuita de los vicios o defectos originados y de los daños y perjuicios directamente ocasionados por ellos. Asimismo, si la reparación no es satisfactoria y el objeto no alcanza las condiciones óptimas para cumplir el uso al que está destinado, el titular de la garantía tendrá derecho a la sustitución del objeto adquirido por otro de idénticas características o la devolución del precio pagado.

Composición: Acabados: baños y/o pinturas epoxi y compuestos de materiales nobles. Estructuras: latón, acero y materiales de fundición. Otros componentes: alabastro, cristal, pantallas de tela, madera y piel.

WARRANTY RIGHTS

LEDS-C4, S.A. guarantees the correct operation of this equipment, repairs or spare parts of the model due to defects in workmanship for 2 years as of the delivery date but accept no responsibility for damages caused through improper use. Claims must be accompanied by a purchase receipt. The company is committed to the free total repair of the faults or defects originated and of the damages and losses directly caused by them. Likewise, if the repair is not satisfactory and the object does not reach the optimal conditions to fulfill the use for which it is intended, the holder of the warranty will have the right to the replacement of the object acquired by another of identical characteristics or the return of the price paid.

- Luminaria en que la protección contra los choques eléctricos no recae exclusivamente sobre el aislamiento principal, sino que comporta una medida de seguridad suplementaria bajo la forma de medios de conexión de las partes conductoras accesibles, a un conductor de protección puesto a tierra, formando parte del cableado fijo de la instalación, de tal manera que las partes conductoras accesibles no puedan llegar a ser peligrosas en caso de defecto del aislamiento principal. / Luminaire in which protection against electric shock does not rely on basic insulation only, but which includes an additional safety precaution in such a way that means are provided for the connection of accessible conductive parts to the protective (earthing) conductor in the fixed wiring of the installation in such a way that accessible conductive parts can not become live in the event of a failure of the basic insulation.
- Luminaria en que la protección contra los choques eléctricos no recae exclusivamente sobre el aislamiento principal, sino que comprende medidas de seguridad suplementarias, tales como el doble aislamiento o el aislamiento reforzado. Estas medidas no comprenden medios de puesta a tierra de protección y no dependen de las condiciones de instalación. / Luminaire in which protection against electric shock does not rely on basic insulation only, but in which additional safety precautions such as double insulation or reinforced insulation are provided, there being no provision for protective earthing or reliance upon installation conditions.
- Distancia mínima de los objetos iluminados (metros). / Minimum distance from lighted objects (meters).
- Sustituir cualquier pantalla de protección con fisuras. / Replace any cracked protective shield.
- Luminarias previstas para el montaje directo sobre superficies normalmente inflamables. / Luminaires suitable for direct mounting on normally flammable surfaces.
- Luminarias para lámparas de vapor de sodio a alta presión que exigen un arrancador exterior (a la lámpara). / Luminaires for use with high pressure sodium lamps that require an external ignitor (to the lamp).
- IP** Sistema de codificación para indicar los grados de protección proporcionados por la envolvente contra el acceso a las partes peligrosas, contra la penetración de agua y contra la penetración de cuerpos sólidos extraños. / Coding system to indicate the degree of protection provided by the enclosure against access to hazardous parts, against the penetration of water and the penetration of solid foreign bodies.

INSTALACION Y MANTENIMIENTO / INSTALLATION AND MAINTENANCE

- Luminaria solo apta para uso exterior. / Luminaire suitable for external use only.
- El cable manguera para la conexión a red en el interior de la luminaria no debe tocar ni la reactancia ni el reflector. / The electrical wire for the connection inside the luminaire should not touch or the ballast or reflector.
- Para mantener el rendimiento óptimo de la luminaria, se requiere la limpieza periódica del vidrio, su frecuencia dependerá de las condiciones ambientales de la instalación. / To maintain optimum performance of the luminaire will require periodic cleaning of the glass, its frequency will depend on the environmental conditions of the installation.
- Se debe desconectar la luminaria del suministro eléctrico antes de proceder al cambio de la lámpara, manipular o realizar cualquier tipo de mantenimiento. Existen altas tensiones dentro de la misma y todas las precauciones tomadas usualmente en la manipulación de equipos de alta tensión deben ser adoptadas igualmente en las operaciones de cambio de lámpara o cualquier otra manipulación. / The luminaire must be disconnected from the power supply before proceeding to change the lamp, manipulate or perform any maintenance. There are high voltages inside the same and usually taken every precaution in handling high voltage equipment must be taken also in the exchange of light or any other manipulation.