

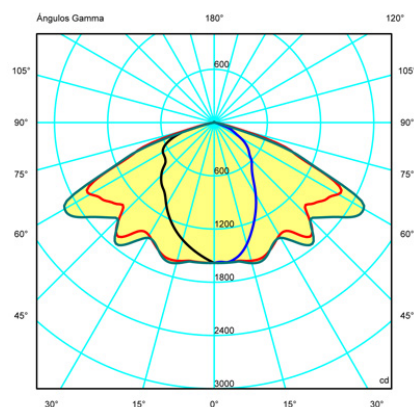

The photograph may not match the reference exactly. Please read the product description to identify the finish.

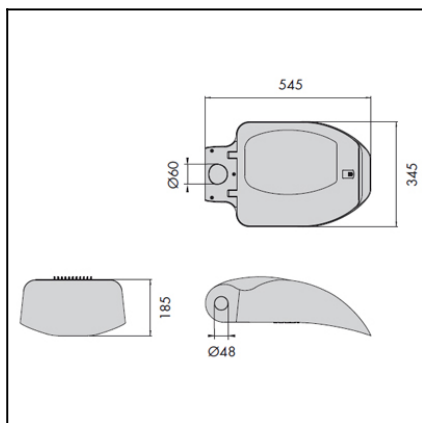

[Download photometric file .ldt / .ies](#)

DESCRIPTION

Designer luminaire for urban and street lighting. Comes with a high grade aluminium reflector and flat toughened glass closure. IP 66 for the optical group. Light casing designed for power ratings from 35W to 150W, using lamp-holders E27, E40 and G12 according to the type of lamp. Magnetic equipment incorporated: Vossloh, ELT.

TECHNICAL CHARACTERISTICS

Type:	Streetlight head
IP Protection degrees:	IP65
IK Protection degrees:	IK08
IP Grup Òptic:	IP66
Lampholder:	1 x E27
Power (W):	E27 HI/HS 70W (VSAP) 2N
Total power consumption (W):	92.3
Voltage / Frequency:	230V/50Hz
Warranty (Years):	2
Units per box:	1
Net Weight (Kg):	8.54
EAN:	8435111078006,00
ULOR (%):	0.52



MATERIALS / FINISHES

Structure material: Injected aluminium

Diffuser material: Tempered glass

Structure finish: Grey

Diffuser finish: Transparent

GEAR

Gear included: Yes, Magnetic
Dimming protocol: bipower with command line

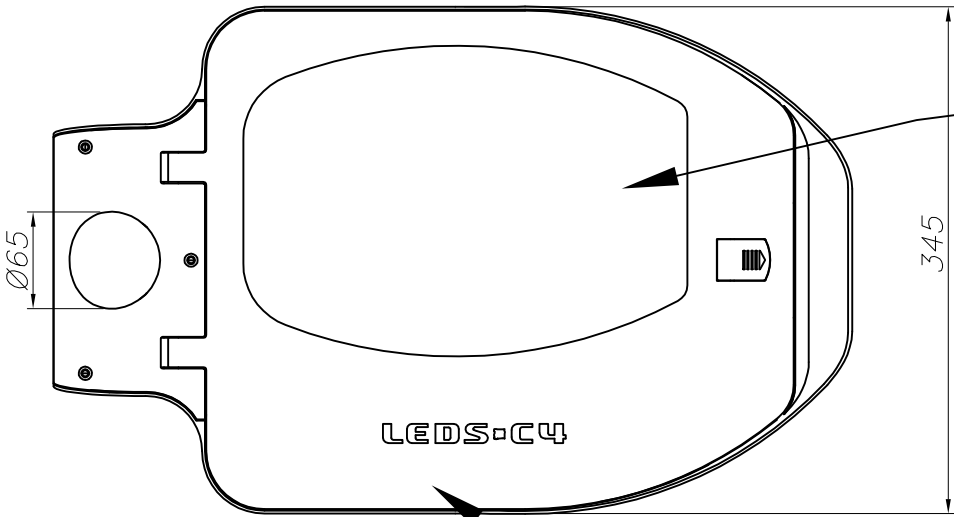

TEMPERED GLASS
/
VIDRE TEMPLAT

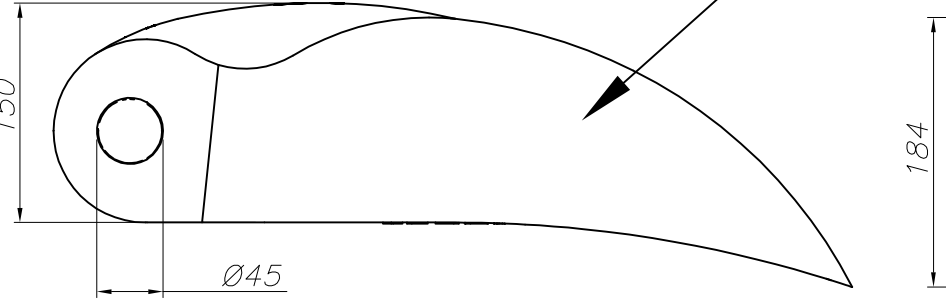

INJECTED ALUMINIUM
/
ALUMINI INJECTAT

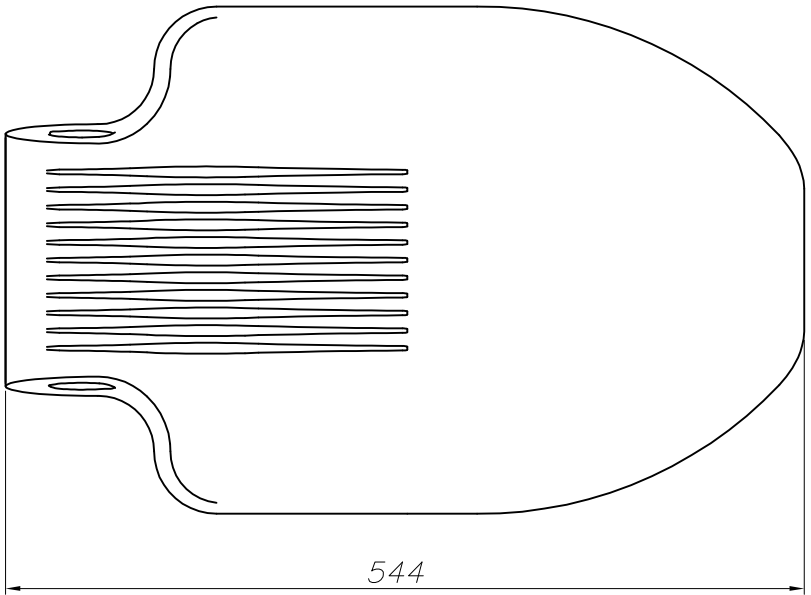
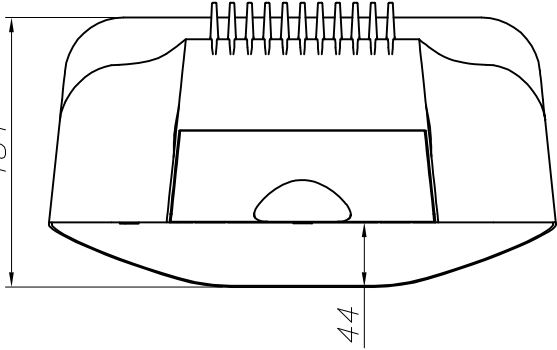

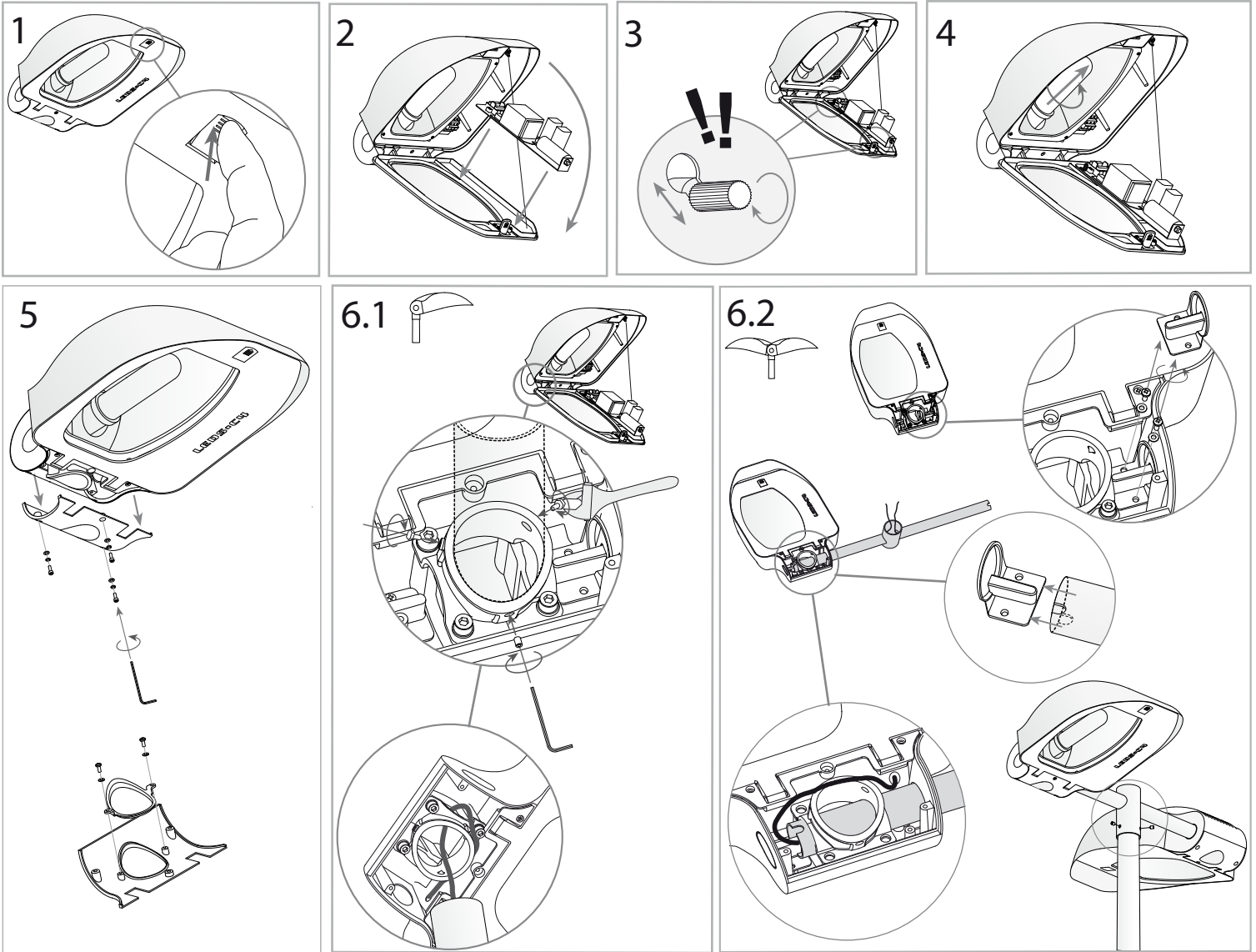

CONEXIONES ELECTRICAS / ELECTRICALS CONNECTIONS

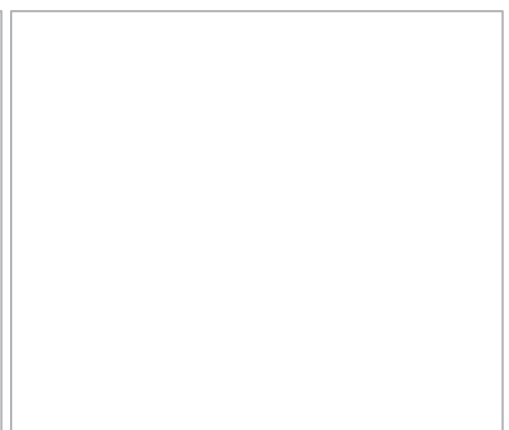
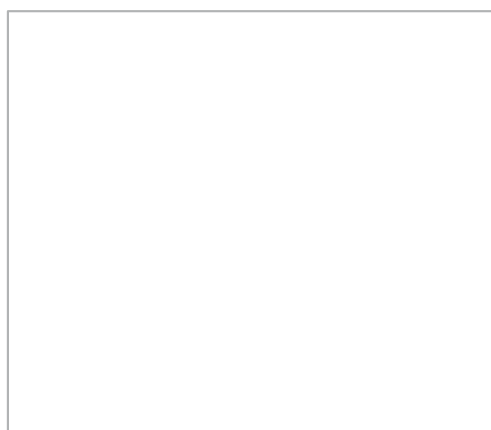
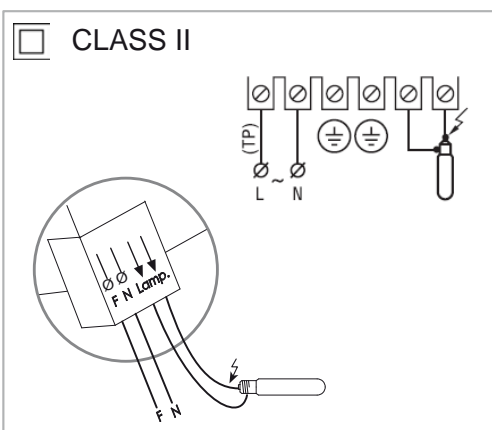
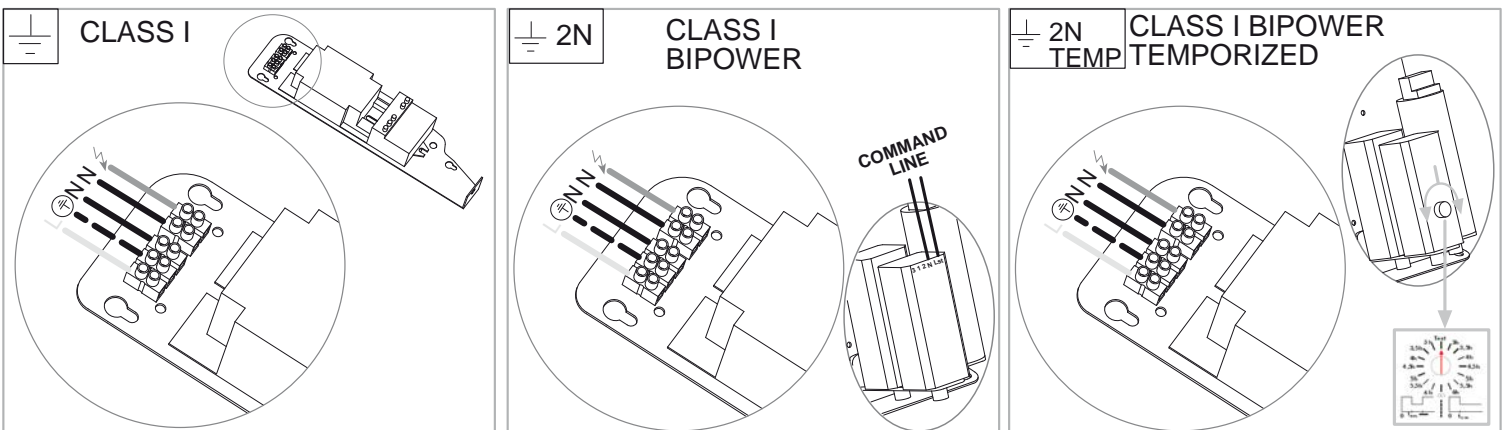

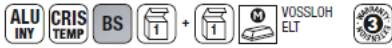

E-27		
70W HPS - MH		80-3044-BS-37
70W HPS	2N	80-3047-BS-37
70W HPS	2N TEMP	80-3054-BS-37
70W HPS - MH		80-3057-BS-37

E40		
100W HPS - MH		80-3045-BS-37
100W HPS	2N	80-3048-BS-37
100W HPS	2N TEMP	80-3055-BS-37
100W HPS - MH		80-3058-BS-37
150W HPS - MH		80-3046-BS-37
150W HPS	2N	80-3049-BS-37
150W HPS	2N TEMP	80-3056-BS-37
150W HPS - MH		80-3059-BS-37

G12		
70W MH		80-4829-BS-37
70W MH		80-4830-BS-37
100W MH		80-4831-BS-37
100W MH		80-4832-BS-37
150W MH		80-4833-BS-37
150W MH		80-4834-BS-37

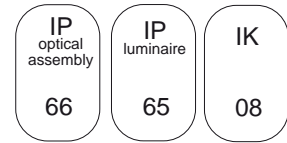
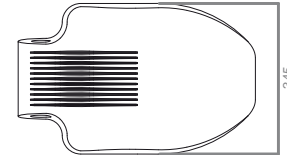
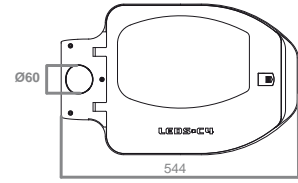

- Todos los productos están fabricados siguiendo las normas de seguridad y electromagnetismo de Europa: EN 60598-1:2004, EN 60598-2-3:2003, EN 55015:2006, EN 61000-3-2:2006, EN61000-3-3:1995, EN 61547 y marcado CE.
 - All products are manufactured according to the European safety norms and electromagnetic standards: EN 60598-1:2004, EN 60598-2-3:2003, EN 55015:2006, EN 61000-3-2:2006, EN61000-3-3:1995, EN 61547 and CE mark.

DERECHOS	DE	GARANTÍA
El fabricante LEDS-C4, S.A. garantiza el correcto funcionamiento del equipo y posibles reparaciones o suministro de recambios del modelo debidos a defectos de fabricación durante 2 años desde la fecha de entrega, pero no puede responsabilizarse de daños y/o perjuicios causados por un mal empleo del mismo. Para cualquier reclamación, se deberá adjuntar a esta garantía el ticket de compra. La empresa se compromete a la reparación total gratuita de los vicios o defectos originados y de los daños y perjuicios directamente ocasionados por ellos. Asimismo, si la reparación no es satisfactoria y el objeto no alcanza las condiciones óptimas para cumplir el uso al que está destinado, el titular de la garantía tendrá derecho a la sustitución del objeto adquirido por otro de idénticas características o la devolución del precio pagado.		
Composition: Acabados: baños y/o pinturas epoxi y compuestos de materiales nobles. Estructuras: latón, acero y materiales de fundición. Otros componentes: alabastro, cristal, pantallas de tela, madera y piel.		
WARRANTY	RIGHTS	
LEDs-C4, S.A. guarantee the correct operation of this equipment, repairs or spare parts of the model due to defects in workmanship for 2 years as of the delivery date but accept no responsibility for damages caused through improper use. Claims must be accompanied by proof of purchase.		
The company agrees to repair any defect or malfunction found in the item and any damages said defect or malfunction might cause directly. Should the repair fail to satisfy the customer and/or the object fail to present the optimum condition for the use for which it is intended, the guarantee holder will be entitled to the replacement of the acquired item with another of identical characteristics or a complete refund of the purchase price.		
Composition: Finishes: plating and/or Epoxy paints and compounds of noble materials. Structure: brass, steel and cast iron. Other components: alabaster, crystal, fabric shades, wood and leather.		

Luminaire en que la protección contra los choques eléctricos no recae exclusivamente sobre el aislamiento principal, sino que comporta una medida de seguridad suplementaria bajo la forma de medios de conexión de las partes conductoras accesibles, a un conductor de protección puesto a tierra, formando parte del cableado fijo de la instalación, de tal manera que las partes conductoras accesibles no puedan llegar a ser peligrosas en caso de defecto del aislamiento principal. / Luminaire in which protection against electric shock does not rely on basic insulation only, but which includes an additional safety precaution in such a way that accessible conductive parts can not become live in the event of a failure of the basic insulation.
Luminaire en que la protección contra los choques eléctricos no recae exclusivamente sobre el aislamiento principal, sino que comprende medidas de seguridad suplementarias, tales como el doble aislamiento o el aislamiento reforzado. Estas medidas no comprenden medios de puesta a tierra de protección y no dependen de las condiciones de instalación. / Luminaire in which protection against electric shock does not rely on basic insulation only, but in which additional safety precautions such as double insulation or reinforced insulation are provided, there being no provision for protective earthing or reliance upon installation conditions.
Distancia mínima de los objetos iluminados (metros). / Minimum distance from lighted objects (meters).
Sustituir cualquier pantalla de protección con fisuras. / Replace any cracked protective shield.
Luminarias previstas para el montaje directo sobre superficies normalmente inflamables. / Luminaires suitable for direct mounting on normally flammable surfaces.
Luminarias para lámparas de vapor de sodio a alta presión que exigen un arrancador exterior (a la lámpara). / Luminaires for use with high pressure sodium lamps that require an external ignitor (to the lamp).
IP Sistema de codificación para indicar los grados de protección proporcionados por la envolvente contra el acceso a las partes peligrosas, contra la penetración de agua y contra la penetración de cuerpos sólidos extraños. / Coding system to indicate the degree of protection provided by the enclosure against access to hazardous parts, against the penetration of water and the penetration of solid foreign bodies.

INSTALACION	Y	MANTENIMIENTO	/	INSTALLATION	AND	MAINTENANCE
- Luminaria solo	apta	para uso exterior.	/	Luminaire suitable for	external	use only.
- El cable manguera para la conexión a red en el interior de la luminaria no debe tocar ni el reflector. / The electrical wire for the connection inside the luminaire should not touch or the ballast or reflector.						
- Para mantener el rendimiento optimo de la luminaria, se requiere la limpieza periódica del vidrio, su frecuencia dependerá de las condiciones ambientales de la instalación. / To maintain optimum performance of the luminaire will require periodic cleaning of the glass, its frequency will depend on the environmental conditions of the installation.						
- Se debe desconectar la luminaria del suministro eléctrico antes de proceder al cambio de la lámpara, manipular o realizar cualquier tipo de mantenimiento. Existen altas tensiones dentro de la misma y todas las precauciones tomadas usualmente en la manipulación de equipos de alta tensión deben ser adoptadas igualmente en las operaciones de cambio de lámpara o cualquier otra manipulación. / The luminaire must be disconnected from the power supply before proceeding to change the lamp, manipulate or perform any maintenance. There are high voltages inside the same and usually taken every precaution in handling high voltage equipment must be taken also in the exchange of light or any other manipulation.						