

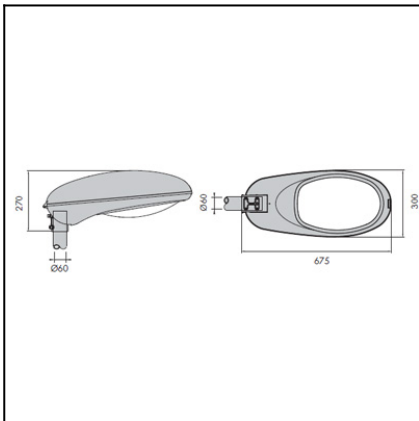

The photograph may not match the reference exactly. Please read the product description to identify the finish.



### DESCRIPTION

Luminaire for street lighting. Comes with a high grade aluminium reflector and a flat toughened glass closure. IP 66 for optical group. Light casing designed for power ratings from 45W to 400W, using lamp-holders E27, E40, G12 or PGZ12, according to the type of lamp. Magnetic equipment incorporated: Vossloh, ELT. Electronic equipment incorporated: Philips.

### TECHNICAL CHARACTERISTICS

Type:	Streetlight head
Adjustable $\pm 15^\circ$ on the horizontal axis.	
IP Protection degrees:	IP64
IK Protection degrees:	IK08
IP Grup Òptic:	IP66
Lampholder:	1 x E40
Power (W):	E40 HS 250W (VSAP) 2N
Total power consumption (W):	265
Voltage / Frequency:	230V/50Hz
Warranty (Years):	2
Units per box:	1
Net Weight (Kg):	9.1
EAN:	8435111074268,00
ULOR (%):	0.58

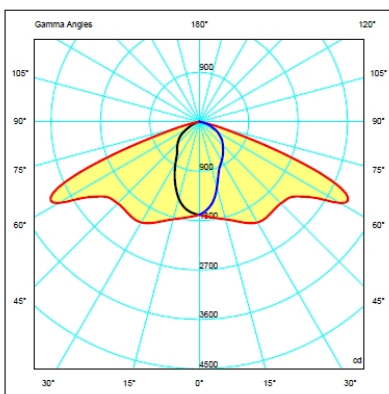
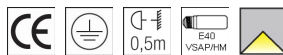

Download photometric file .ldt / .ies

### MATERIALS / FINISHES

<b>Structure material:</b>	Injected aluminium	<b>Diffuser material:</b>	Tempered glass
<b>Structure finish:</b>	Pearl grey	<b>Diffuser finish:</b>	Bended and transparent

### GEAR

Gear included: Yes, Magnetic

<b>Luminaria</b>		<b>Ensayo</b>		<b>Lámpara</b>		
Código	URB0027 250W VSAP	Código	URB0027 250W VSAP	Código	SON-Tpia plus 250W	
Nombre	Cabezal URB0027 250W VSAP E40	Nombre	Cabezal URB0027 250W VSAP E40	Número	1	
Familia	- LEDS C4	Fecha	18-12-2012	Posición	Universal	
Rendimiento	72.30%	Sist. de Coorden.	C-G Viales	Flujo Total	33200.00 lm	
Valor Máximo	11206.88 cd	Posición	C=15.00 G=60.00	Sim. en los planos 270-90		
Luminaria Rectangular	Longit.	680 mm	Anchura	300 mm	Altura	200 mm
Área Luminosa Rectangular	Longit.	300 mm	Anchura	230 mm	Altura	0 mm
Área Luminosa Horizontal	0.069000 m2		Área Emisión sobre Pl. 180°		0.000000 m2	
Área Emisión sobre Pl. 0°	0.000000 m2		Área Emisión sobre Pl. 270°		0.000000 m2	
Área Emisión sobre Pl. 90°	0.000000 m2		Área de deslumbramiento a 76°		0.016693 m2	
Tipo de Simetría	Sim. en los planos 270-90		Máximo Ángulo Gamma		180	
Distancia de Ensayo	6.44		Flujo de Ensayo		29313.00 lm	
Operador	Asselum T2		Tensión de alimentación		230.00 V	
Temperatura	20.00 °C		Corriente de alimentación		PRC	
Humedad	48.00 %		Fotocélula			
Notas						

Lámparas de la Luminaria					
Familia	Código	Nombre	Flujo/lm	Pot.W	Cant.
PHILIPS 2005 ILCOS ST,SD,SE,LS	SON-Tpia plus 250W	MASTER SON-T pia plus 250W E40	33200.00	250.00	1
C.I.E.	48 81 98 99 72	D DIN 5040	A31		

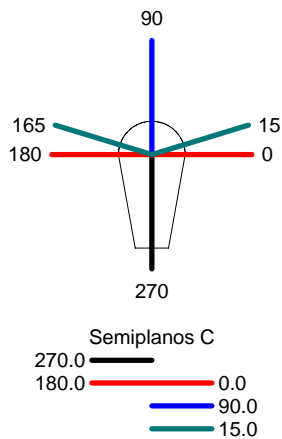

ULOR 0.58 %  
DLOR 71.72 %  
RN 0.80 %

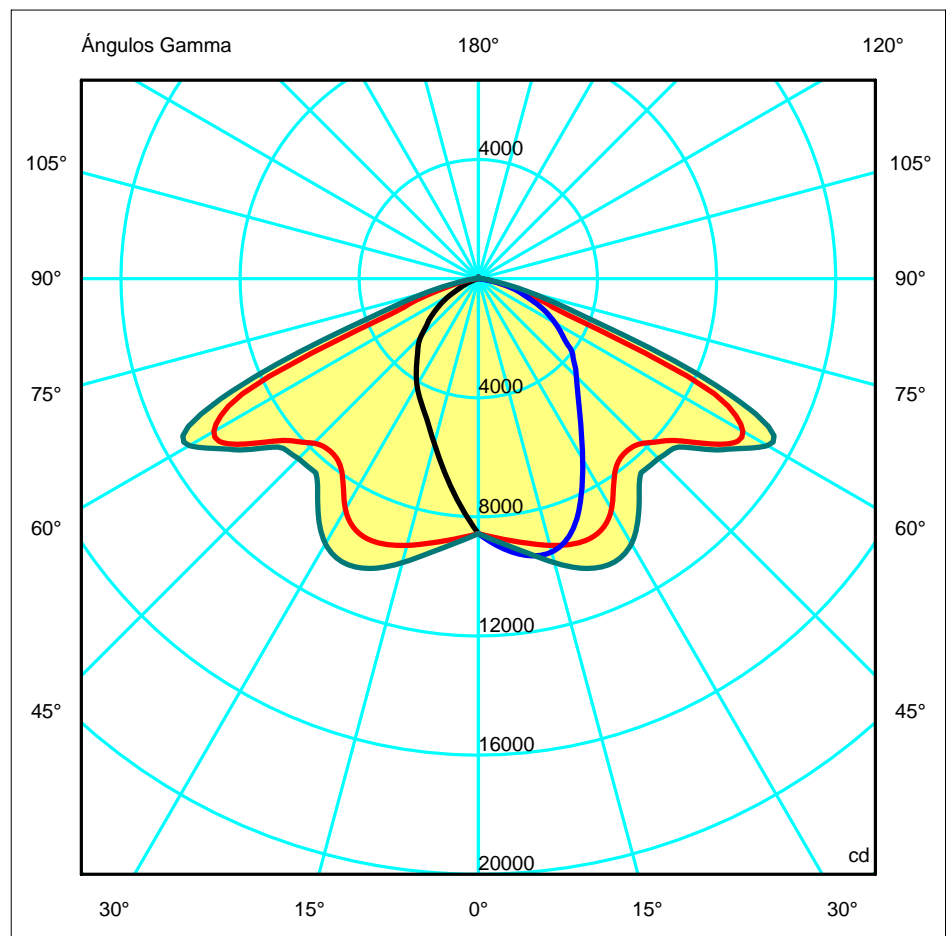

TEMPERED GLASS  
/  
VIDRE TEMPLAT

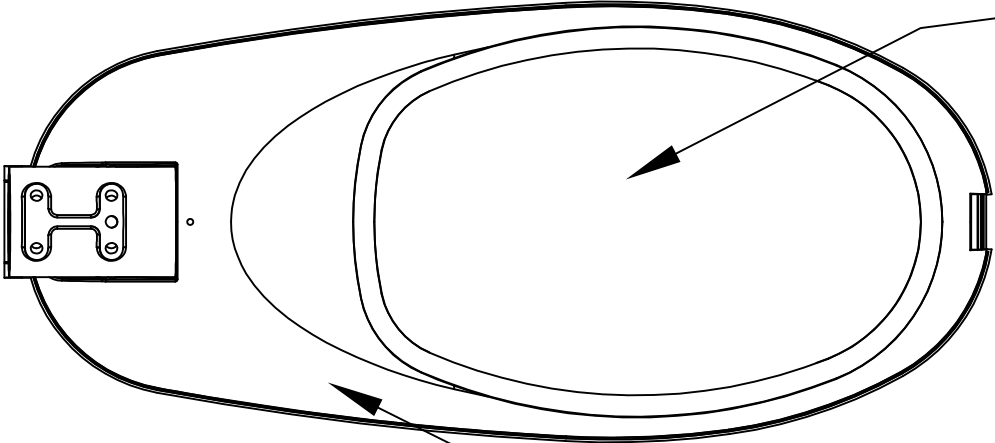

INJECTED ALUMINIUM  
/  
ALUMINI INJECTAT

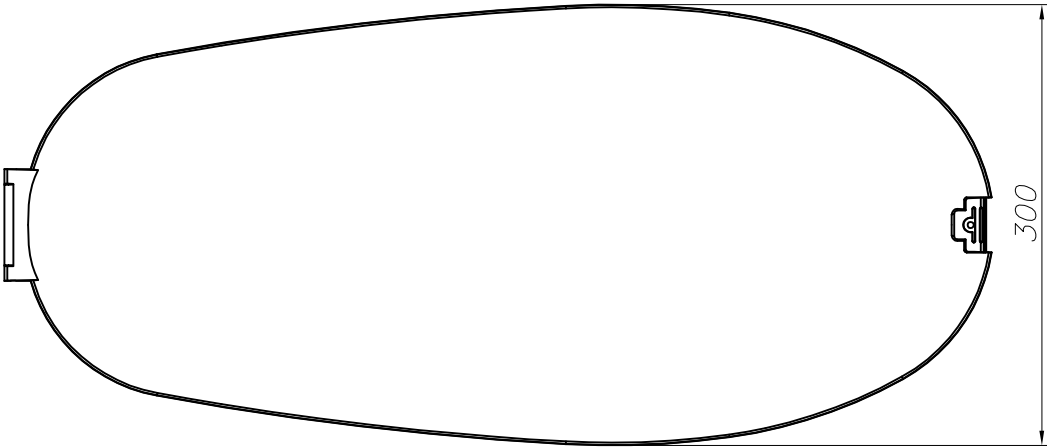
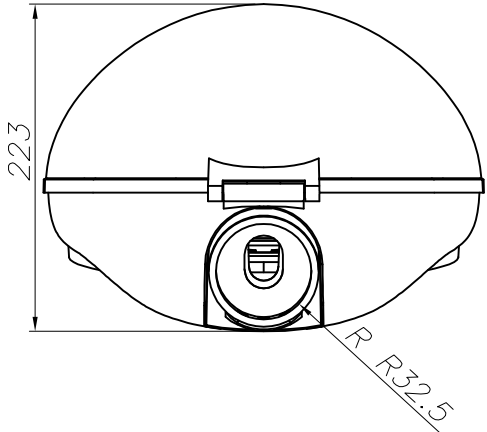
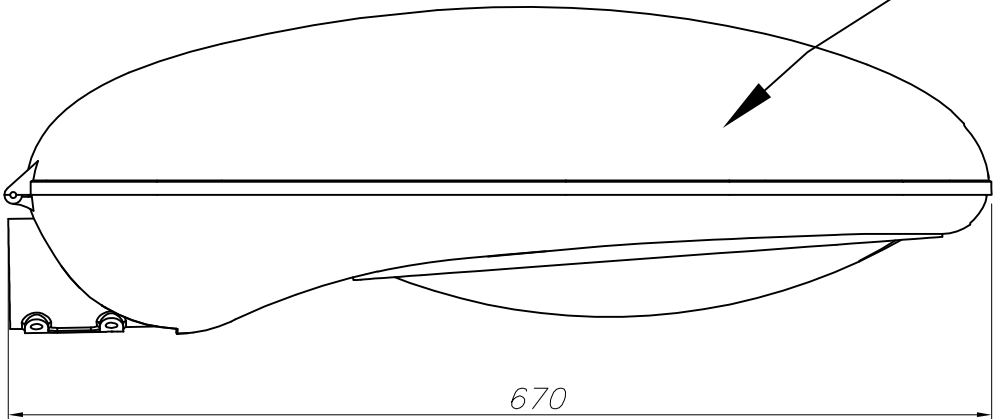

**1**

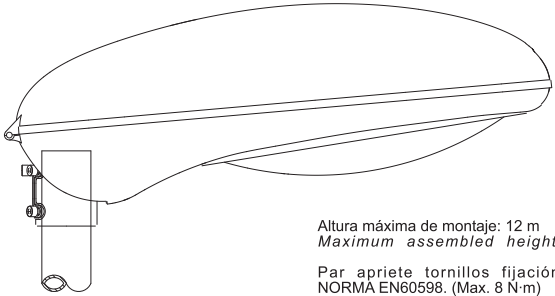
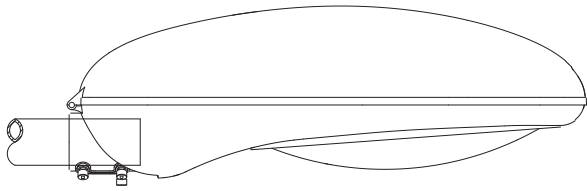

Altura máxima de montaje: 12 m  
Maximum assembled height: 12 m  
Par apriete tornillos fijación según  
NORMA EN60598. (Max. 8 N·m)  
Fastening screw tightness torque  
according to NORM EN60598. (Max. 8 N·m)

**2**

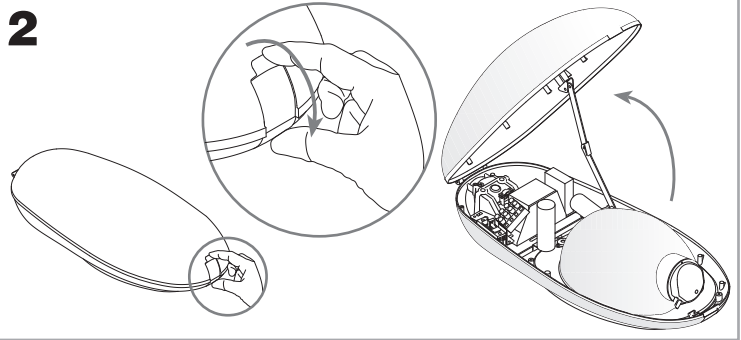

**3**

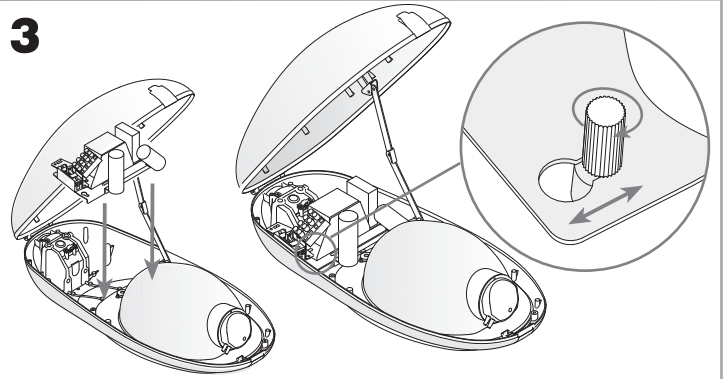

**4**

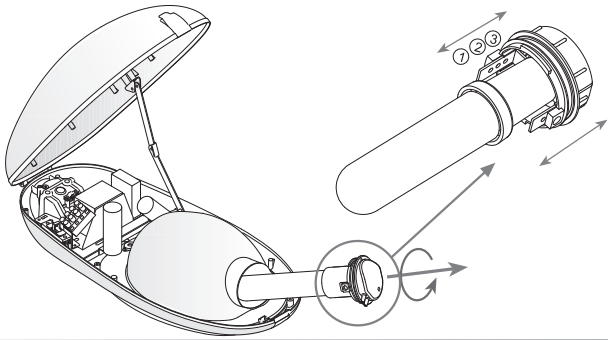

**5**

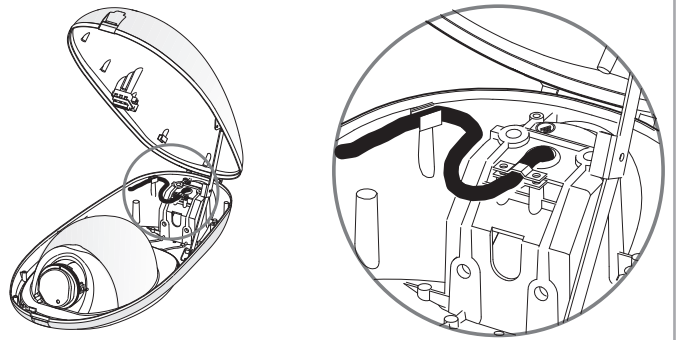

**CONEXIONES ELECTRICAS / ELECTRICALS CONNECTIONS**

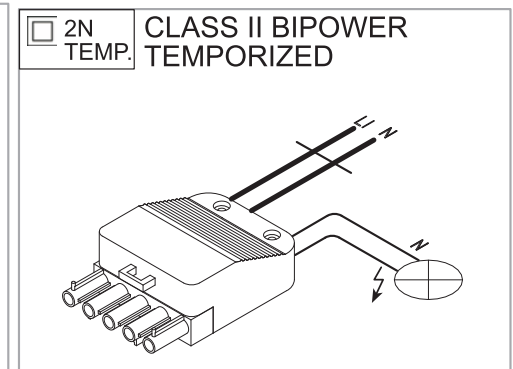
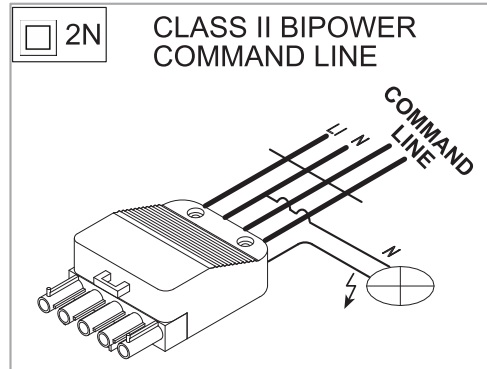
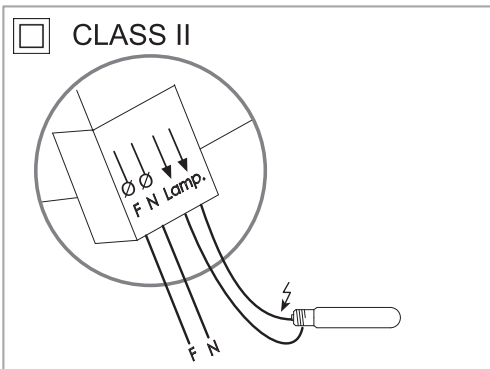
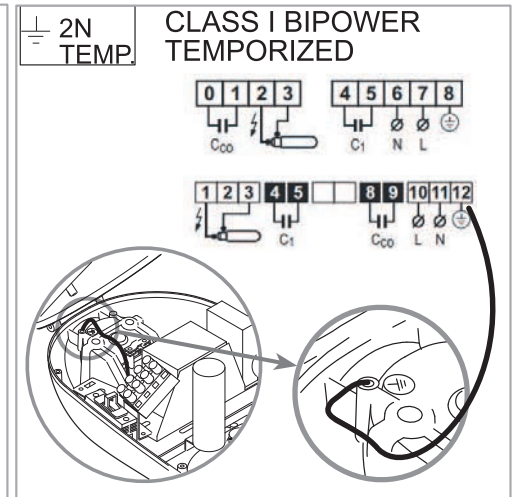
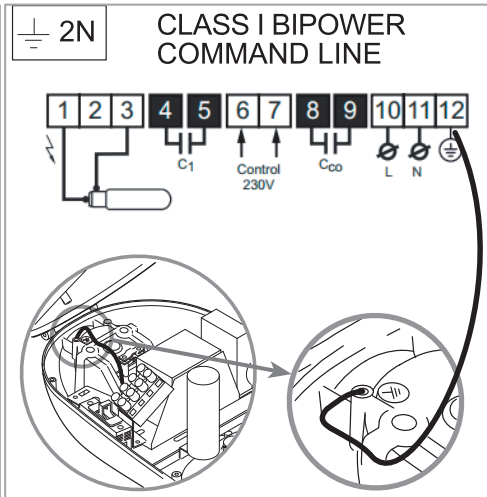
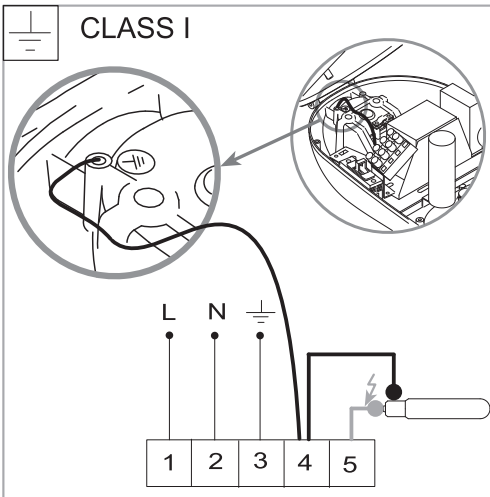



E-27		
70W	HPS - MH	80-3071-AT-37
70W	HPS	80-3074-AT-37
70W	HPS	80-3083-AT-37
70W	HPS - MH	80-3087-AT-37
70W	HPS	80-3091-AT-37
70W	HPS	80-3095-AT-37

E-40		
WITHOUT GEAR		
100W	HPS - MH	80-4771-AT-37
100W	HPS	80-3072-AT-37
100W	HPS	80-3075-AT-37
100W	HPS	80-3084-AT-37
100W	HPS - MH	80-3088-AT-37
100W	HPS	80-3092-AT-37
100W	HPS	80-3096-AT-37
150W	HPS - MH	80-3073-AT-37
150W	HPS	80-3076-AT-37
150W	HPS	80-3085-AT-37
150W	HPS - MH	80-3089-AT-37
150W	HPS	80-3093-AT-37
150W	HPS	80-3097-AT-37
250W	HPS - MH	80-3081-AT-37
250W	HPS	80-3082-AT-37
250W	HPS	80-3086-AT-37
250W	HPS - MH	80-3090-AT-37
250W	HPS	80-3094-AT-37
250W	HPS	80-3098-AT-37
400W	HPS - MH	80-2674-AT-37
400W	HPS	80-3252-AT-37
400W	HPS	80-3253-AT-37

G-12		
70W	MH	80-4838-AT-37
70W	MH	80-4839-AT-37
100W	MH	80-4840-AT-37
100W	MH	80-4841-AT-37
150W	MH	80-4842-AT-37
150W	MH	80-4843-AT-37

PGZ-12		
45W	COSMOWHITE	80-4598-AT-37
60W	COSMOWHITE	80-4599-AT-37
90W	COSMOWHITE	80-4600-AT-37
140W	COSMOWHITE	80-4601-AT-37

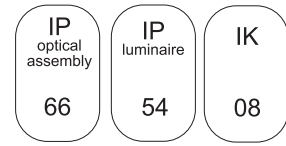
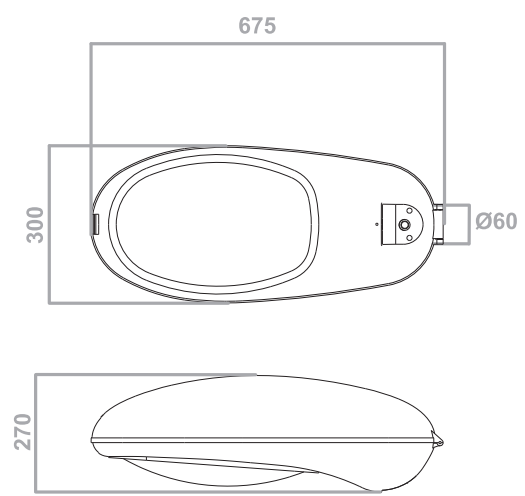

CE

- Todos los productos están fabricados siguiendo las normas de seguridad y electromagnetismo de Europa: EN 60598-1:2004, EN 60598-2-3:2003, EN 55015:2006, EN 61000-3-2:2006, EN61000-3-3:1995, EN 61547 y marcado CE.

- All products are manufactured according to the European safety norms and electromagnetic standards: EN 60598-1:2004, EN 60598-2-3:2003, EN 55015:2006, EN 61000-3-2:2006, EN61000-3-3:1995, EN 61547 and CE mark.

Luminaria en que la protección contra los choques eléctricos no recae exclusivamente sobre el aislamiento principal, sino que comporta una medida de seguridad suplementaria bajo la forma de medios de conexión de las partes conductoras accesibles, a un conductor de protección puesto a tierra, formando parte del cableado fijo de la instalación, de tal manera que las partes conductoras accesibles no puedan llegar a ser peligrosas en caso de defecto del aislamiento principal. / Luminaire in which protection against electric shock does not rely on basic insulation only, but which includes an additional safety precaution in such a way that means are provided for the connection of accessible conductive parts to the protective (earthing) conductor in the fixed wiring of the installation in such a way that accessible conductive parts can not become live in the event of a failure of the basic insulation.

Luminaria en que la protección contra los choques eléctricos no recae exclusivamente sobre el aislamiento principal, sino que comprende medidas de seguridad suplementarias, tales como el doble aislamiento o el aislamiento reforzado. Estas medidas no comprenden medios de puesta a tierra de protección y no dependen de las condiciones de instalación. / Luminaire in which protection against electric shock does not rely on basic insulation only, but in which additional safety precautions such as double insulation or reinforced insulation are provided, there being no provision for protective earthing or reliance upon installation conditions.

Distancia mínima de los objetos iluminados (metros). / Minimum distance from lighted objects (meters).

Sustituir cualquier pantalla de protección con fisuras. / Replace any cracked protective shield.

Luminarias previstas para el montaje directo sobre superficies normalmente inflamables. / Luminaires suitable for direct mounting on normally flammable surfaces.

Luminarias para lámparas de vapor de sodio a alta presión que exigen un arrancador exterior (a la lámpara). / Luminaires for use with high pressure sodium lamps that require an external ignitor (to the lamp).

**IP** Sistema de codificación para indicar los grados de protección proporcionados por la envolvente contra el acceso a las partes peligrosas, contra la penetración de agua y contra la penetración de cuerpos sólidos extraños. / Coding system to indicate the degree of protection provided by the enclosure against access to hazardous parts, against the penetration of water and the penetration of solid foreign bodies.

**INSTALACION Y MANTENIMIENTO / INSTALLATION AND MAINTENANCE**

- Luminaria solo apta para uso exterior. / Luminaire suitable for external use only.
- El cable manguera para la conexión a red en el interior de la luminaria no debe tocar ni la reactancia ni el reflector. / The electrical wire for the connection inside the luminaire should not touch or the ballast or reflector.
- Para mantener el rendimiento óptimo de la luminaria, se requiere la limpieza periódica del vidrio, su frecuencia dependerá de las condiciones ambientales de la instalación. / To maintain optimum performance of the luminaire will require periodic cleaning of the glass, its frequency will depend on the environmental conditions of the installation.
- Se debe desconectar la luminaria del suministro eléctrico antes de proceder al cambio de la lámpara, manipular o realizar cualquier tipo de mantenimiento. Existen altas tensiones dentro de la misma y todas las precauciones tomadas usualmente en la manipulación de equipos de alta tensión deben ser adoptadas igualmente en las operaciones de cambio de lámpara o cualquier otra manipulación. / The luminaire must be disconnected from the power supply before proceeding to change the lamp, manipulate or perform any maintenance. There are high voltages inside the same and usually taken every precaution in handling high voltage equipment must be taken also in the exchange of light or any other manipulation.