

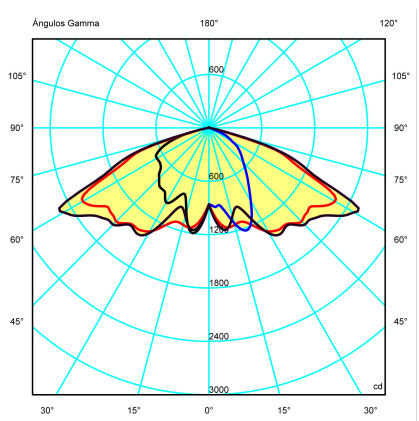

The photograph may not match the reference exactly. Please read the product description to identify the finish.

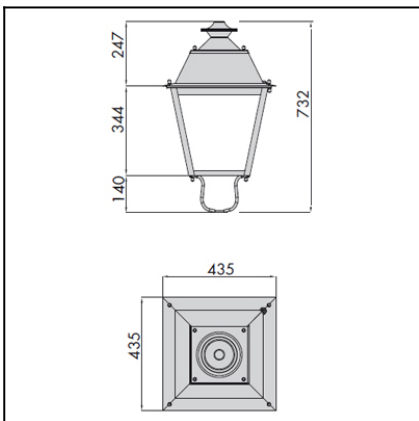

[Download photometric file .ldt / .ies](#)

DESCRIPTION

Classically styled luminaire adapted to the new light pollution and energy efficiency requirements. For urban lighting. Incorporates a high grade aluminium reflector for horizontal lamp fitting, does not incorporate polycarbonate diffuser. Installation of the luminaire in TOP position. Fitting to 3/4" thread with Ø60mm using an accessory (not included on the light casing). IP 65 for the optical group. Light casing suitable for power ratings from 35W to 150W, using lamp-holders E27, E40 or G12, according to the discharge lamp to be used. Magnetic equipment incorporated: Vossloh, ELT.

TECHNICAL CHARACTERISTICS

| | |
|------------------------------|--------------------------|
| Type: | Streetlight head |
| IP Protection degrees: | IP44 |
| IK Protection degrees: | IK08 |
| IP Grup Òptic: | IP65 |
| Lampholder: | 1 x E40 |
| Power (W): | E40 HI/HS 100W (VSAP/HM) |
| Total power consumption (W): | 124.9 |
| Voltage / Frequency: | 230V/50Hz |
| Warranty (Years): | 2 |
| Units per box: | 1 |
| Net Weight (Kg): | 8.73 |
| EAN: | 8435111079041,00 |
| ULOR (%): | 0.55 |

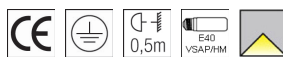

MATERIALS / FINISHES

| | |
|---|--|
| Structure material: Galvanized steel | Diffuser material: Tempered glass |
| Structure finish: Baked-on black forge | Diffuser finish: Transparent |

GEAR

Gear included: Yes, Magnetic

| Luminaria | | Ensayo | | Lámpara | |
|----------------------------|-------------------------------|-------------------------------|-------------------------------|---------------------------|--------------------|
| Código | ANDALU 100WVSAP ASIM | Código | ANDALU 150WVSAP ASIM | Código | SON-Tpia plus 100W |
| Nombre | ANDALUCIA 100W VSAP asimetric | Nombre | ANDALUCIA 150W VSAP asimetric | Número | 1 |
| Familia | - LEDS C4 | Fecha | 13-03-2012 | Posición | Universal |
| Rendimiento | 58.25% | Sist. de Coorden. | C-G Viales | Flujo Total | 10700.00 lm |
| Valor Máximo | 3079.58 cd | Posición | C=10.00 G=60.00 | Sim. en los planos 270-90 | |
| Luminaria Rectangular | Longit. 430 mm | Anchura | 430 mm | Altura | 290 mm |
| Área Luminosa Rectangular | Longit. 240 mm | Anchura | 140 mm | Altura | 0 mm |
| Área Luminosa Horizontal | 0.033600 m2 | Área Emisión sobre Pl. 180° | | 0.000000 m2 | |
| Área Emisión sobre Pl. 0° | 0.000000 m2 | Área Emisión sobre Pl. 270° | | 0.000000 m2 | |
| Área Emisión sobre Pl. 90° | 0.000000 m2 | Área de deslumbramiento a 76° | | 0.008129 m2 | |
| Tipo de Simetría | Sim. en los planos 270-90 | Máximo Ángulo Gamma | 180 | | |
| Distancia de Ensayo | 6.44 | Flujo de Ensayo | 17206.00 lm | | |
| Operador | Asselum T2 | Tensión de alimentación | 230.00 V | | |
| Temperatura | 20.00 °C | Corr. aliment. | | | |
| Humedad | 50.00 % | Fotocélula | PRC | | |
| Notas | | | | | |

| Lámparas de la Luminaria | | | | | |
|--------------------------------|--------------------|--------------------------------|----------|--------|-------|
| Familia | Código | Nombre | Flujo/lm | Pot.W | Cant. |
| PHILIPS 2005 ILCOS ST,SD,SE,LS | SON-Tpia plus 100W | MASTER SON-T pia plus 100W E40 | 10700.00 | 100.00 | 1 |
| C.I.E. | 41 77 98 99 58 | D DIN 5040 | A31 | | |

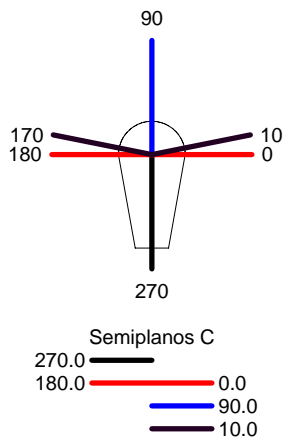

ULOR 0.55 %
DLOR 57.70 %
RN 0.95 %

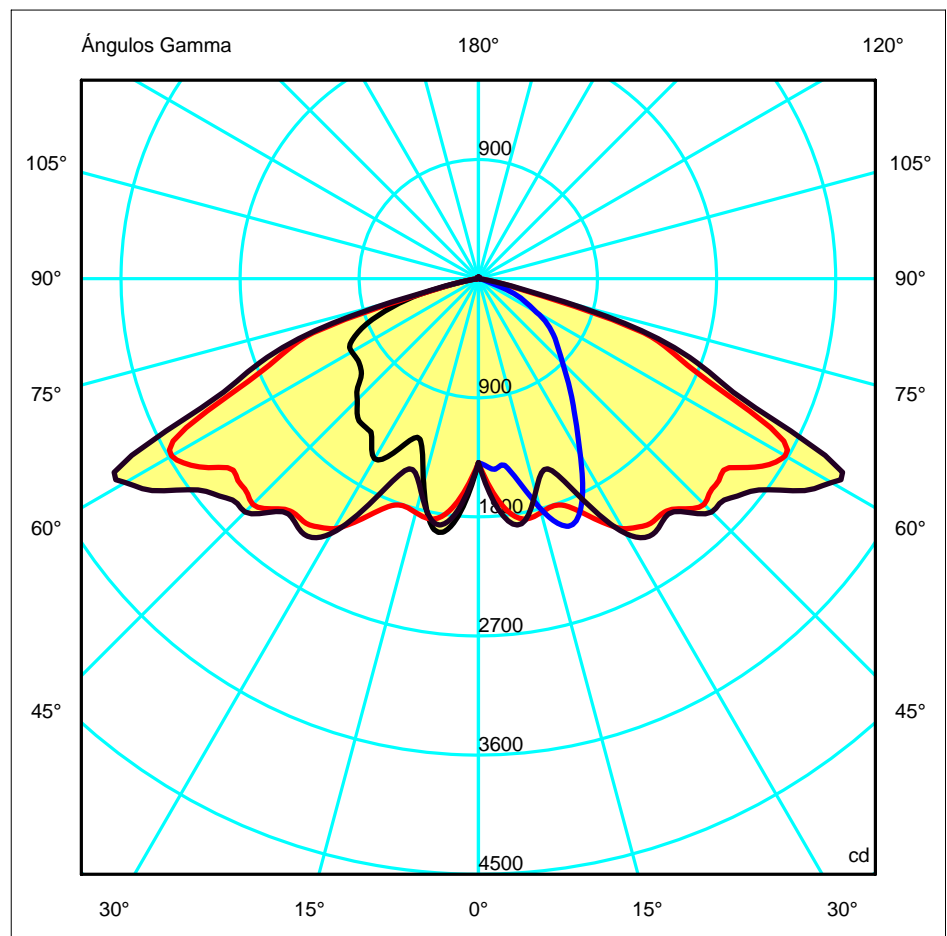

TEMPERED GLASS / VIDRE TEMPLAT

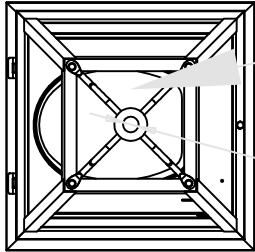

$\varnothing 27.5$

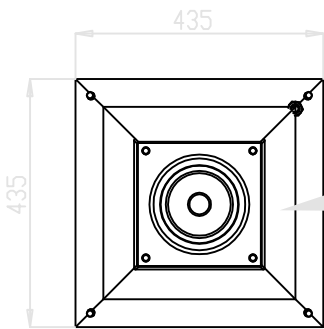
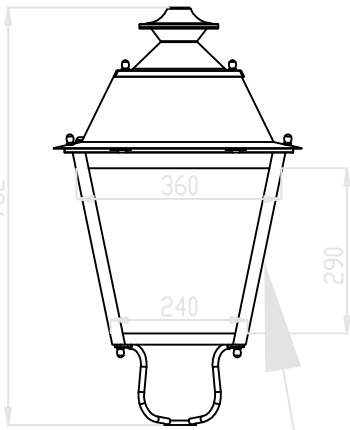
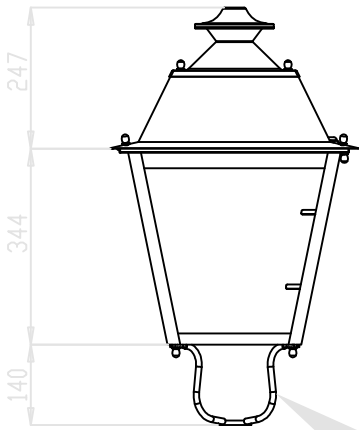

GALVANIZED AND PAINTED STEEL /
ACER GALVANITZAT I PINTAT

1

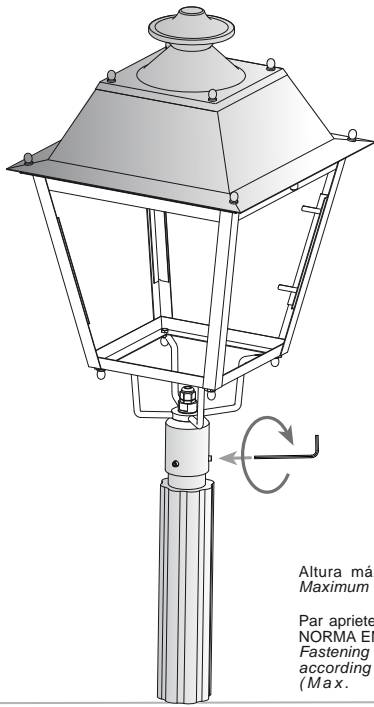

Altura máxima de montaje: 5 m
Maximum assembled height: 5m

Par apriete tornillos fijación según
NORMA EN60598. (Max. 1,2 N·m)
Fastening screw tightness torque
according to NORM EN60598.
(Max. 1,2 N·m)

2

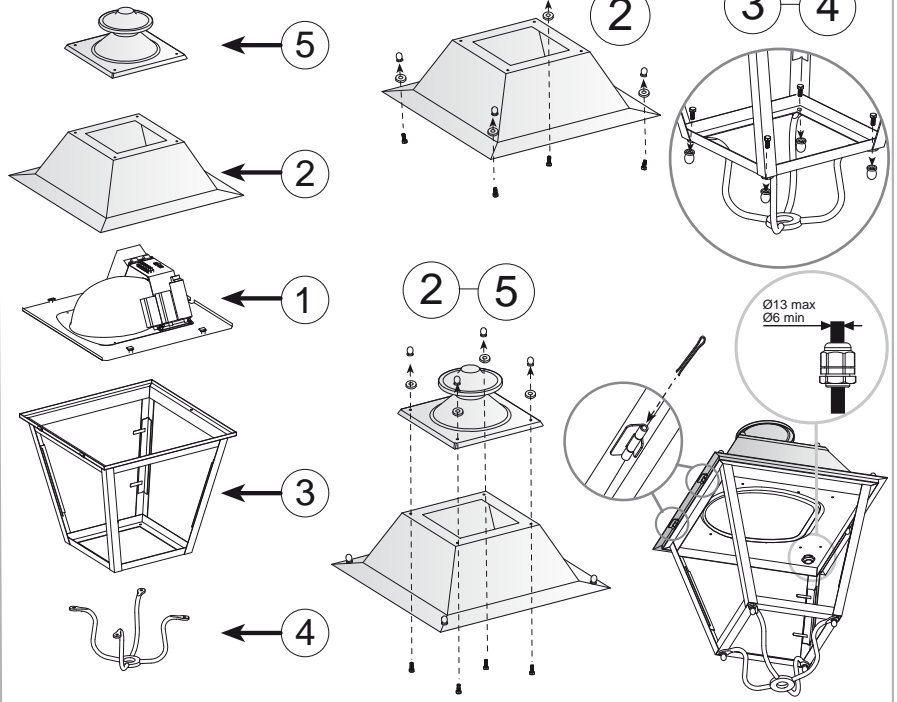

3

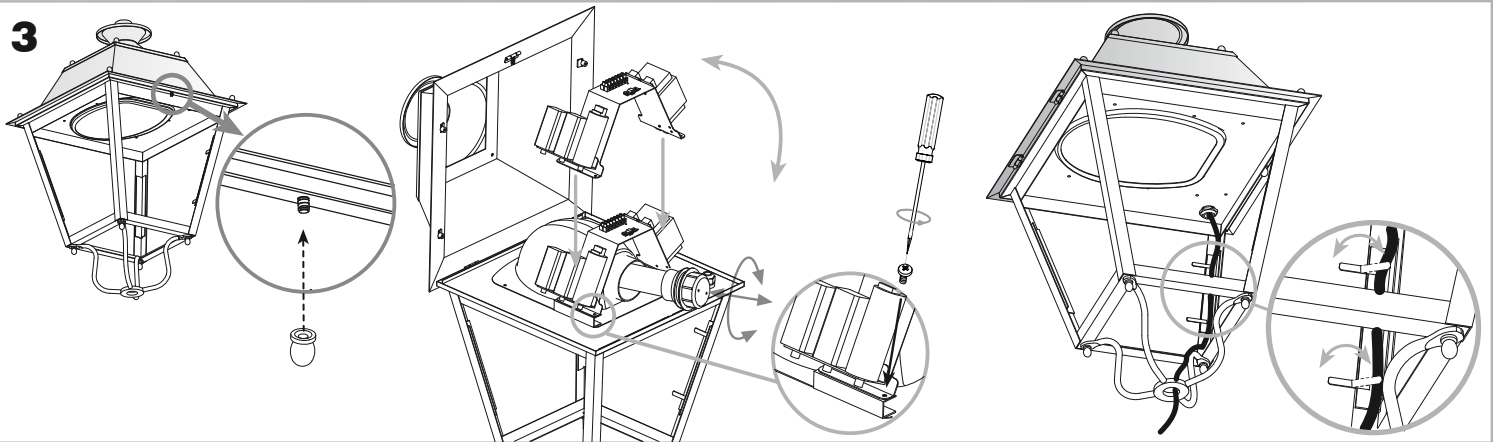

CONEXIONES ELECTRICAS / ELECTRICAL CONNECTIONS

CLASS I

CLASS I BIPOWER

CLASS I BIPOWER TEMP. TEMPORIZED

CLASS II

CLASS II BIPOWER COMMAND LINE

CLASS II BIPOWER TEMP. TEMPORIZED

| COD | CLASS | kg | | | | |
|--------------|----------|-----|----------------------------|-----|-----------------------------|--|
| 80-4470-BP-3 | | 8,7 | 70 | E27 | OSRAM - VIALOX NAV-T 70 4Y | |
| | | | | | OSRAM - HCI-TT 70/830 | |
| 80-4471-BP-3 | | 8,9 | 100 | E40 | OSRAM - VIALOX NAV-T 100 | |
| | | | | | OSRAM - HCI-TT | |
| 80-4472-BP-3 | | 9,7 | 150 | E40 | OSRAM - VIALOX NAV-T 150 4Y | |
| | | | | | OSRAM - HCI-TT | |
| 80-4473-BP-3 | 2N | 9 | 50 / 70 | E27 | OSRAM - VIALOX NAV-T 70 4Y | |
| 80-4474-BP-3 | 2N | 9,2 | 70 / 100 | E40 | OSRAM - VIALOX NAV-T 100 | |
| 80-4475-BP-3 | 2N | 9,7 | 100 / 150 | E40 | OSRAM - VIALOX NAV-T 150 4Y | |
| 80-4476-BP-3 | 2N TEMP. | 9 | 50 / 70 | E27 | OSRAM - VIALOX NAV-T 70 4Y | |
| 80-4477-BP-3 | 2N TEMP. | 9,2 | 70 / 100 | E40 | OSRAM - VIALOX NAV-T 100 | |
| 80-4478-BP-3 | 2N TEMP. | 9,7 | 100 / 150 | E40 | OSRAM - VIALOX NAV-T 150 4Y | |
| 80-4479-BP-3 | | 9,1 | 70 | E27 | OSRAM - VIALOX NAV-T 70 4Y | |
| | | | | | OSRAM - HCI-TT 70/830 | |
| 80-4480-BP-3 | | 9,5 | 100 | E40 | OSRAM - VIALOX NAV-T 100 | |
| | | | | | OSRAM - HCI-TT | |
| 80-4481-BP-3 | | 10 | 150 | E40 | OSRAM - VIALOX NAV-T 150 | |
| | | | | | OSRAM - HCI-TT | |
| 80-4482-BP-3 | 2N | 9,2 | 50 / 70 | E27 | OSRAM - VIALOX NAV-T 70 4Y | |
| 80-4483-BP-3 | 2N | 9,7 | 70 / 100 | E40 | OSRAM - VIALOX NAV-T 100 | |
| 80-4484-BP-3 | 2N | 9,9 | 100 / 150 | E40 | OSRAM - VIALOX NAV-T 150 4Y | |
| 80-4485-BP-3 | 2N TEMP. | 9,2 | 50 / 70 | E27 | OSRAM - VIALOX NAV-T 70 4Y | |
| 80-4486-BP-3 | 2N TEMP. | 9,7 | 70 / 100 | E40 | OSRAM - VIALOX NAV-T 100 | |
| 80-4487-BP-3 | 2N TEMP. | 9,9 | 100 / 150 | E40 | OSRAM - VIALOX NAV-T 150 4Y | |
| 80-4492-BP-3 | | 7,5 | SIN EQUIPOS / WITHOUT GEAR | E40 | SIN EQUIPOS / WITHOUT | |

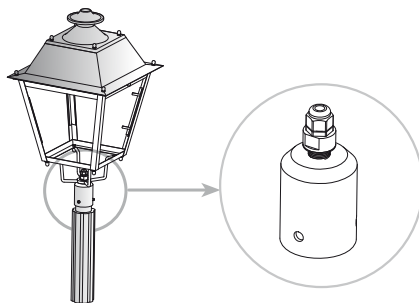
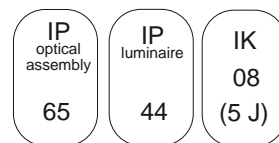
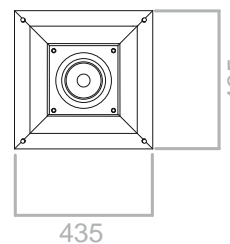
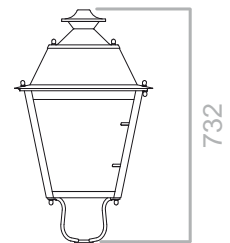
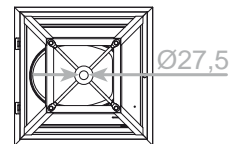

71-4470-BP-B



- Todos los productos están fabricados siguiendo las normas de seguridad y electromagnetismo de Europa: EN 60598-1:2004, EN 60598-2-3:2003, EN 55015:2006, EN 61000-3-2:2006, EN61000-3-3:1995, EN 61547 y marcado CE.
- All products are manufactured according to the European safety norms and electromagnetic standards: EN 60598-1:2004, EN 60598-2-3:2003, EN 55015:2006, EN 61000-3-2:2006, EN61000-3-3:1995, EN 61547 and CE mark.

| DERECHOS | DE | GARANTÍA |
|---|----|---------------|
| El fabricante LEDS-C4, S.A. garantiza el correcto funcionamiento del equipo y posibles reparaciones o suministro de recambios del modelo debidos a defectos de fabricación durante 2 años desde la fecha de entrega, pero no puede responsabilizarse de daños y/o perjuicios causados por un mal empleo del mismo. Para cualquier reclamación, se deberá adjuntar a esta garantía el ticket de compra. La empresa se compromete a la reparación total gratuita de los vicios o defectos originados y de los daños y perjuicios directamente ocasionados por ellos. Asimismo, si la reparación no es satisfactoria y el objeto no alcanza las condiciones óptimas para cumplir el uso al que está destinado, el titular de la garantía tendrá derecho a la sustitución del objeto adquirido por otro de idénticas características o la devolución del precio pagado. | | |
| WARRANTY LEDS-C4, S.A. guarantee the correct operation of this equipment, repairs or spare parts of the model due to defects in workmanship for 2 years as of the delivery date but accept no responsibility for damages caused through improper use. Claims must be accompanied by proof of purchase. The company agrees to repair any defect or malfunction found in the item and any damages said defect or malfunction might cause directly. Should the repair fail to satisfy the customer and/or the object fail to present the optimum condition for the use for which it is intended, the guarantee holder will be entitled to the replacement of the acquired item with another of identical characteristics or a complete refund of the purchase price. | | RIGHTS |
| Composition: Finishes: plating and/or Epoxy paints and compounds of noble materials. Structure: brass, steel and cast iron. Other components: alabaster, crystal, fabric shades, wood and leather. | | |

| | |
|-----------|---|
| | Luminaria en que la protección contra los choques eléctricos no recae exclusivamente sobre el aislamiento principal, sino que comporta una medida de seguridad suplementaria bajo la forma de medios de conexión de las partes conductoras accesibles, a un conductor de protección puesto a tierra, formando parte del cableado fijo de la instalación, de tal manera que las partes conductoras accesibles no puedan llegar a ser peligrosas en caso de defecto del aislamiento principal. / Luminaire in which protection against electric shock does not rely on basic insulation only, but which includes an additional safety precaution in such a way that means are provided for the connection of accessible conductive parts to the protective (earthing) conductor in the fixed wiring of the installation in such a way that accessible conductive parts can not become live in the event of a failure of the basic insulation. |
| | Luminaria en que la protección contra los choques eléctricos no recae exclusivamente sobre el aislamiento principal, sino que comprende medidas de seguridad suplementarias, tales como el doble aislamiento o el aislamiento reforzado. Estas medidas no comprenden medios de puesta a tierra de protección y no dependen de las condiciones de instalación. / Luminaire in which protection against electric shock does not rely on basic insulation only, but in which additional safety precautions such as double insulation or reinforced insulation are provided, there being no provision for protective earthing or reliance upon installation conditions. |
| | Distancia mínima de los objetos iluminados (metros). / Minimum distance from lighted objects (meters). |
| | Sustituir cualquier pantalla de protección con fisuras. / Replace any cracked protective shield. |
| | Luminarias previstas para el montaje directo sobre superficies normalmente inflamables. / Luminaires suitable for direct mounting on normally flammable surfaces. |
| | Luminarias para lámparas de vapor de sodio a alta presión que exigen un arrancador exterior (a la lámpara). / Luminaires for use with high pressure sodium lamps that require an external ignitor (to the lamp). |
| IP | Sistema de codificación para indicar los grados de protección proporcionados por la envolvente contra el acceso a las partes peligrosas, contra la penetración de agua y contra la penetración de cuerpos sólidos extraños. / Coding system to indicate the degree of protection provided by the enclosure against access to hazardous parts, against the penetration of water and the penetration of solid foreign bodies. |

| INSTALACION | Y | MANTENIMIENTO | / | INSTALLATION | AND | MAINTENANCE |
|--|------|---------------|------|--------------|----------|---|
| Luminaria | solo | apta | para | uso | externo. | / Luminaire suitable for external use only. |
| - El cable manguera para la conexión a red en el interior de la luminaria no debe tocar ni la reactancia ni el reflector. / The electrical wire for the connection inside the luminaire should not touch or the ballast or reflector. | | | | | | |
| - Para mantener el rendimiento óptimo de la luminaria, se requiere la limpieza periódica del vidrio, su frecuencia dependerá de las condiciones ambientales de la instalación. / To maintain optimum performance of the luminaire will require periodic cleaning of the glass, its frequency will depend on the environmental conditions of the installation. | | | | | | |
| - Se debe desconectar la luminaria del suministro eléctrico antes de proceder al cambio de la lámpara, manipular o realizar cualquier tipo de mantenimiento. Existen altas tensiones dentro de la misma y todas las precauciones tomadas usualmente en la manipulación de equipos de alta tensión deben ser adoptadas igualmente en las operaciones de cambio de lámpara o cualquier otra manipulación. / The luminaire must be disconnected from the power supply before proceeding to change the lamp, manipulate or perform any maintenance. There are high voltages inside the same and usually taken every precaution in handling high voltage equipment must be taken also in the exchange of light or any other manipulation. | | | | | | |