

# PROMENADE DESCARGA

## 80-4505-BQ-37

OUT 



The photograph may not match the reference exactly. Please read the product description to identify the finish.

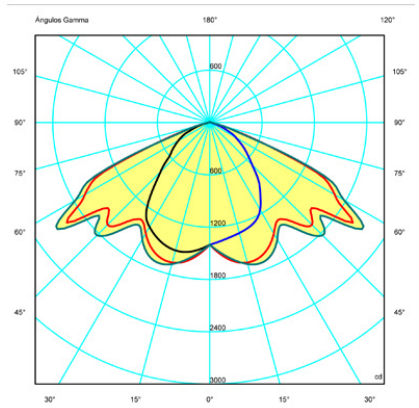
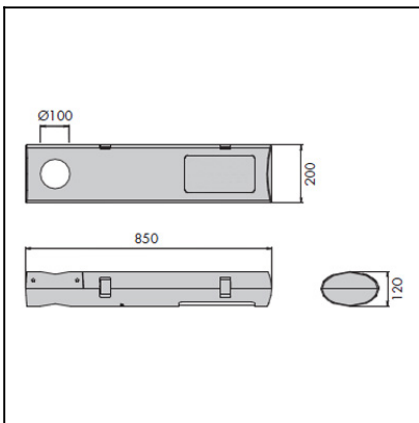

Download photometric file .ldt / .ies

### DESCRIPTION

Designer luminaire for urban lighting. Comes with a high grade aluminium reflector and curved toughened glass closure. IP 66 for optical group. Light casing designed for power ratings from 35W to 150W, using lamp-holders E27, E40, G12 and PGZ12, according to the type of lamp. Magnetic equipment incorporated: Vossloh, ELT. Electronic equipment incorporated: Philips.

### TECHNICAL CHARACTERISTICS

Type:	Streetlight head
IP Protection degrees:	IP66
IK Protection degrees:	IK08
IP Grup Òptic:	IP66
Lampholder:	1 x E27
Power (W):	E27 70W (VSAP)
Total power consumption (W):	92.3
Voltage / Frequency:	230V/50Hz
Warranty (Years):	2
Units per box:	1
Net Weight (Kg):	7.57
EAN:	8435111084212,00
ULOR (%):	0.58

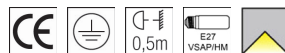

### MATERIALS / FINISHES

<b>Structure material:</b>	Injected aluminium	<b>Diffuser material:</b>	Tempered glass
<b>Structure finish:</b>	Baked-on black forge	<b>Diffuser finish:</b>	Bended and transparent

### GEAR

Gear included: Yes, Magnetic  
Dimming protocol: bipower with command line

<b>Luminaria</b>		<b>Ensayo</b>		<b>Lámpara</b>	
Código	80-4505	Código	PROMENADE150 25-1-11	Código	SON-Tpia plus 70W
Nombre	PROMENADE VSAP70 W FINAL	Nombre	PROMENADE VSAP 150 W	Número	1
Familia	- LEDS C4	Fecha	25-01-2011	Posición	Universal
Rendimiento	74.88%	Sist. de Coordin.	C-G Viales	Flujo Total	6600.00 lm
Valor Máximo	2131.72 cd	Posición	C=15.00 G=55.00	Sim. en los planos	270-90

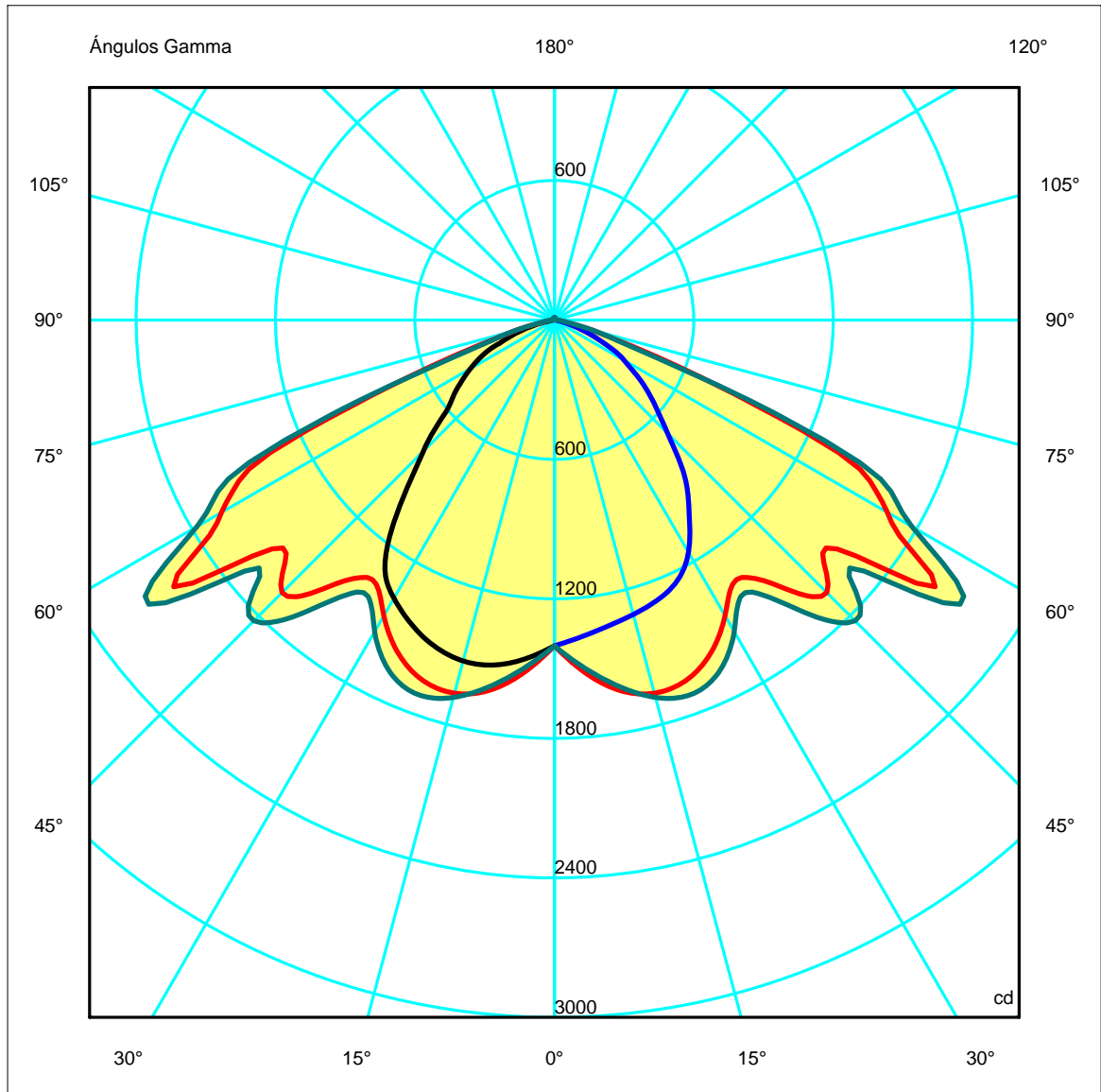
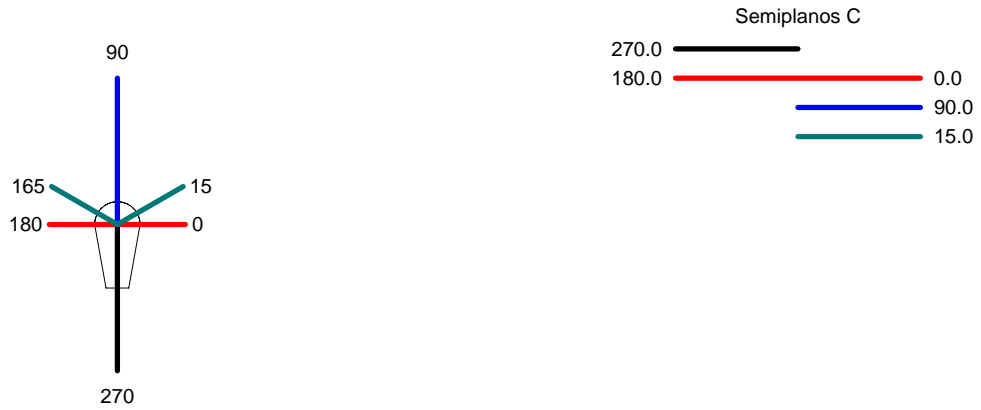

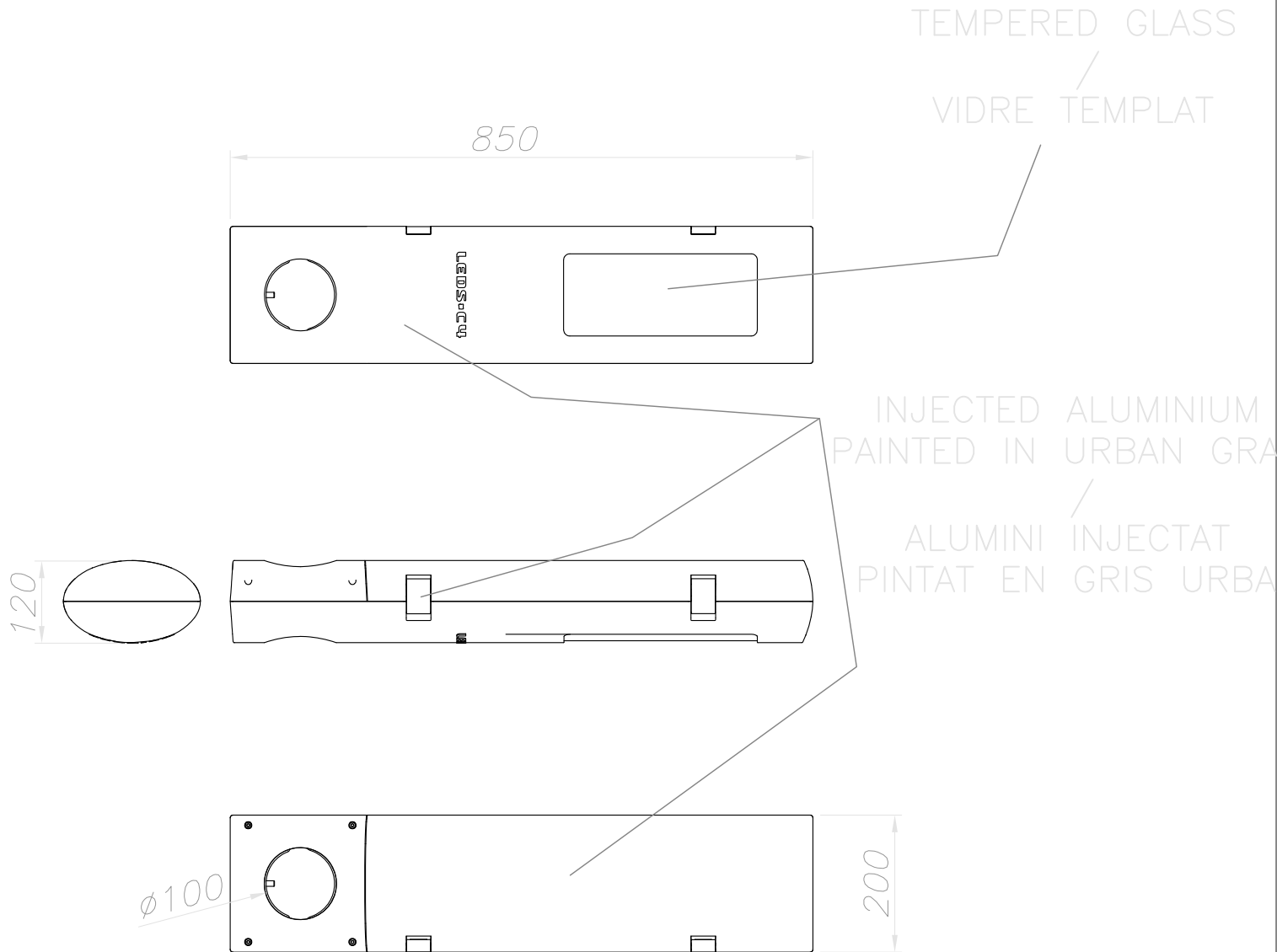

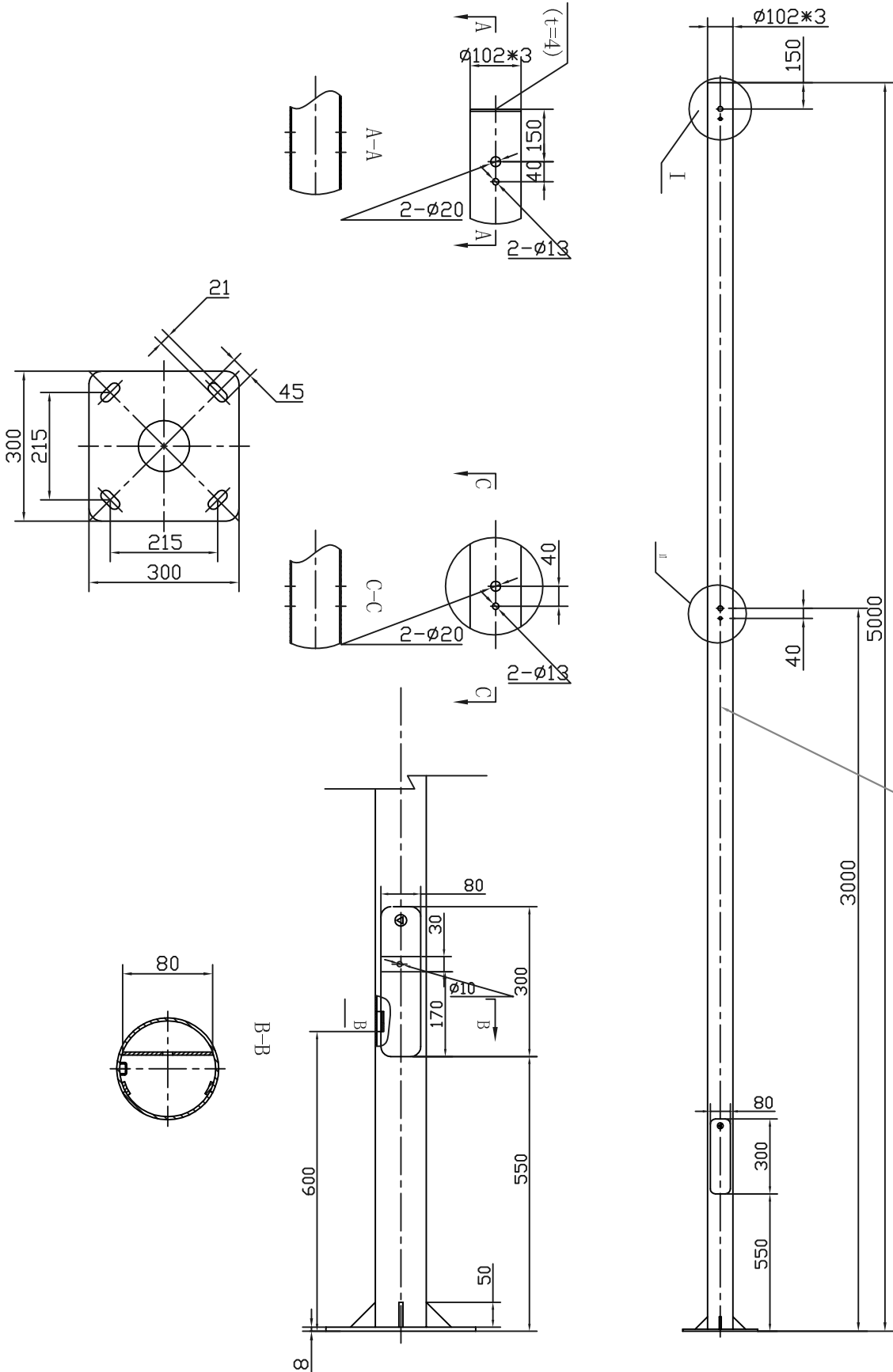

ACER AL CARBONI  
S-235-JR,  
GALVANIZAT PER  
IMMERSIÓ EN  
CALENT I PINTAT  
EN COLOR GRIS  
ALUMINI ACABAT AL  
FORN.

HOT-DIPPED  
GALVANISED  
CARBON STEEL  
S-235-JR IN  
ALUMINIUM GREY,  
BAKED FINISH.

4 UNITS

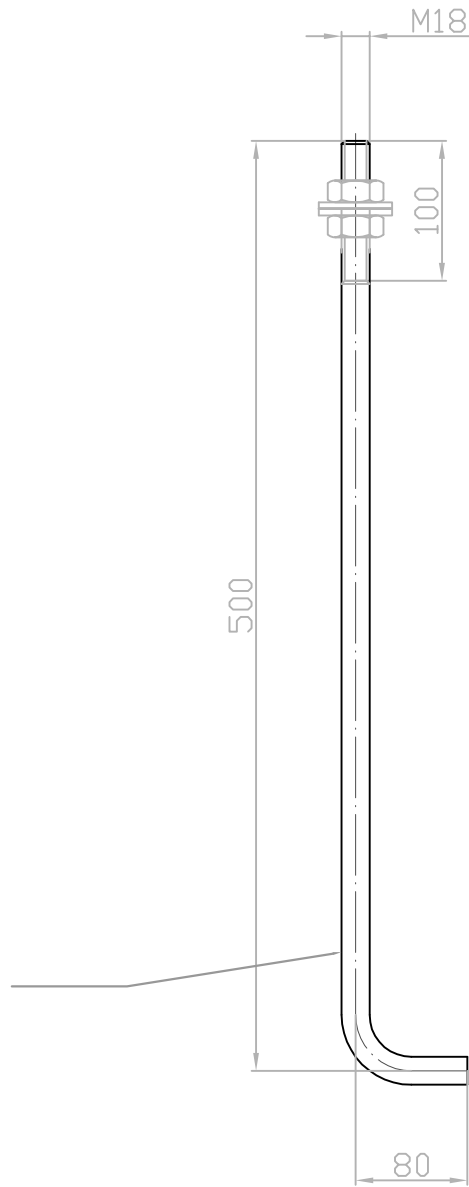

ANCHOR BOLTS

ACER AL CARBONI  
S-235-JR ZINCAT.

ZINQUED CARBON STEEL  
S-235-JR

ACER AL CARBONI  
S-235-JR ZINCAT.

ZINQUED CARBON STEEL  
S-235-JR

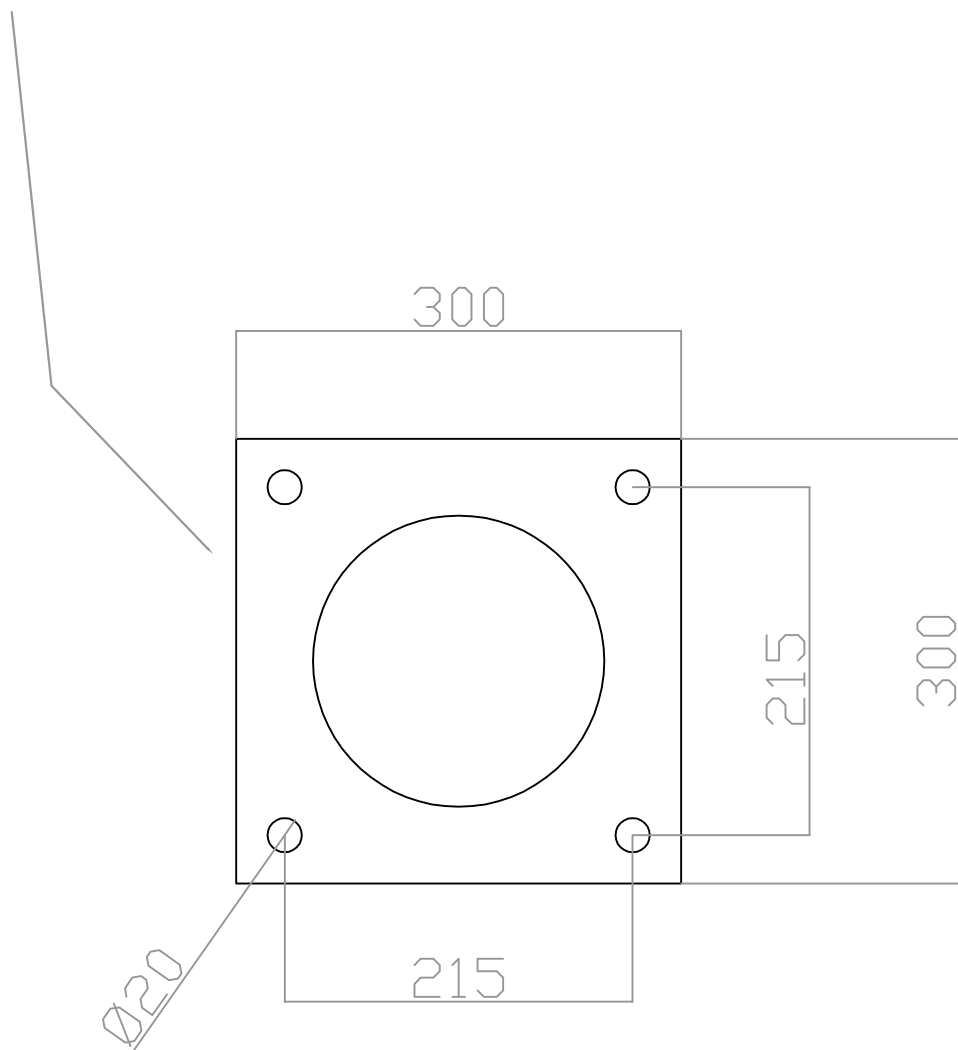

**1**

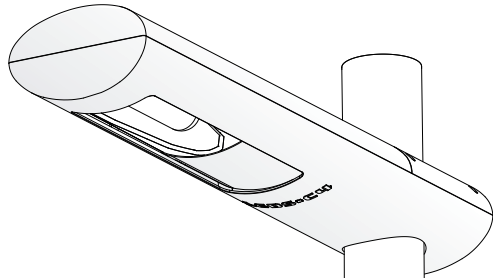

Altura máxima de montaje: 7 m  
Maximum assembled height: 7 m

Par apriete tornillos fijación según  
NORMA EN60598. (Max. 8 N·m)  
Fastening screw tightness torque  
according to NORM EN60598. (Max. 8 N·m)

**2**

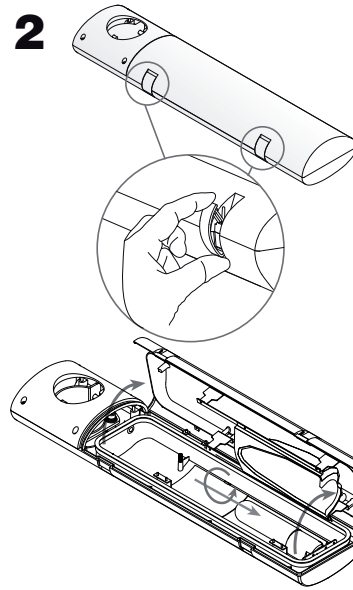

**3**

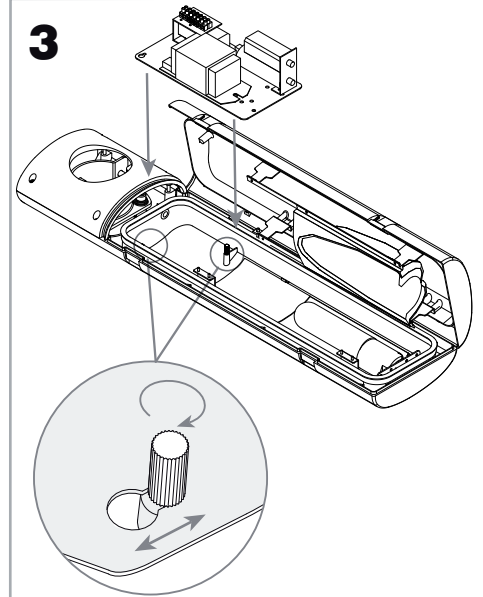

**4**

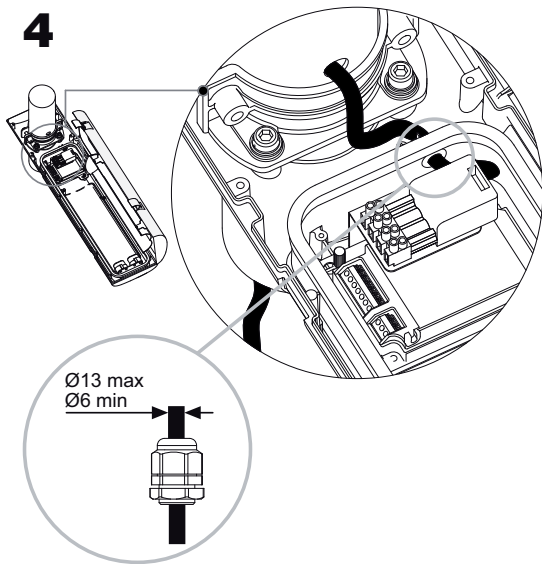

**5.1**

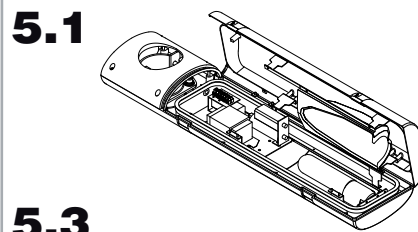

**5.2**

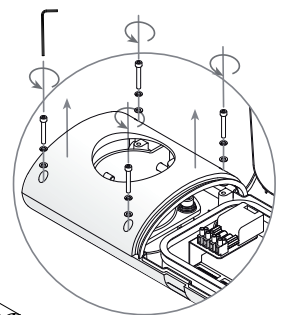

**5.3**

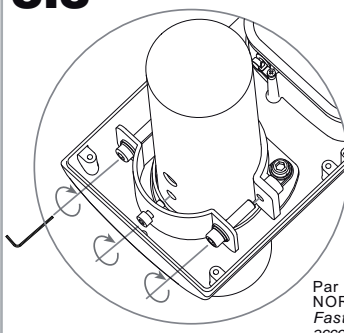

**5.4**

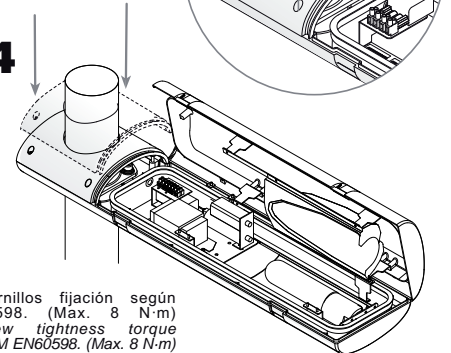

Par apriete tornillos fijación según  
NORMA EN60598. (Max. 8 N·m)  
Fastening screw tightness torque  
according to NORM EN60598. (Max. 8 N·m)

## CONEXIONES ELECTRICAS / ELECTRICAL CONNECTIONS

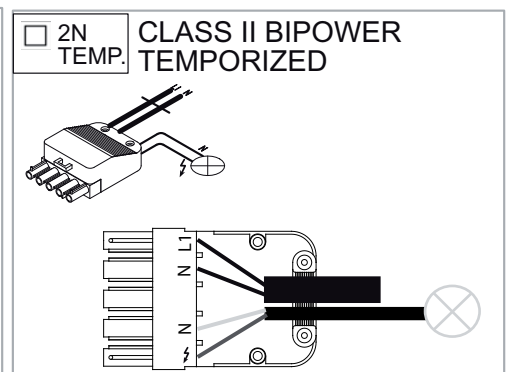
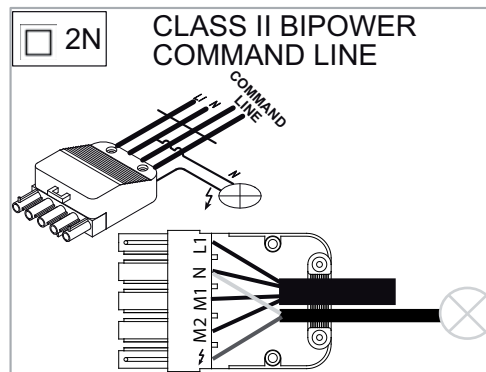
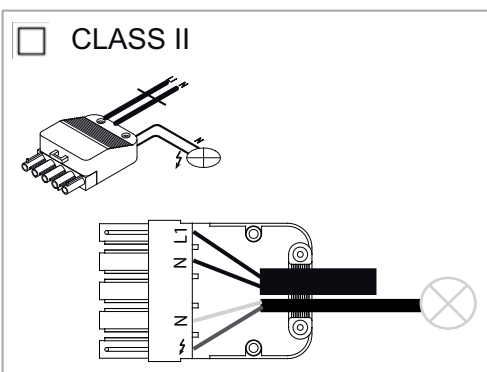
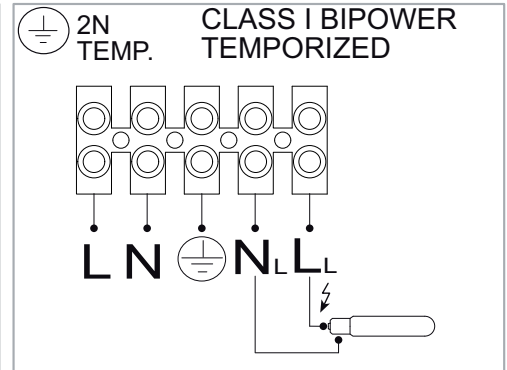
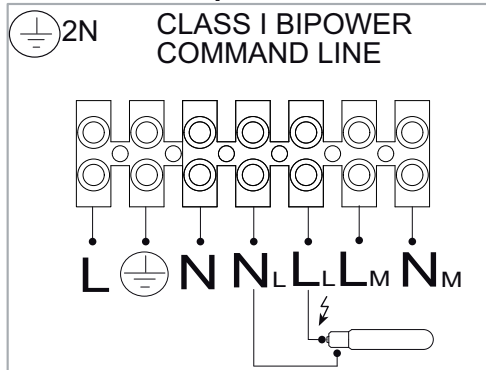
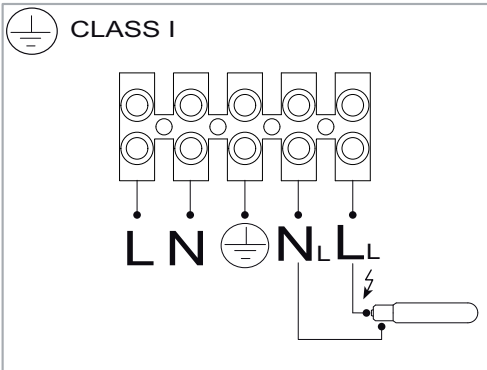

CODE	CLASS	HEIGHT	W			
83-4542-AX-37	⊕	3 M	35	G12	OSRAM - HIC-T 35/830 WDL PB	
83-4543-AX-37	⊕	3 M	70	G12	OSRAM - HIC-T 70/830 WDL PB	
83-4544-AX-37	□	3 M	35	G12	OSRAM - HIC-T 35/830 WDL PB	
83-4545-AX-37	□	3 M	70	G12	OSRAM - HIC-T 70/830 WDL PB	
83-4546-AX-37	⊕	3 M	70	E27	OSRAM - VIALOX NAV-T 70 4Y OSRAM - HCI-TT 70/830 WDL PB	
83-4547-AX-37	⊕ 2N	3 M	50 / 70	E27	OSRAM - VIALOX NAV-T 70 4Y	
83-4548-AX-37	⊕ 2N TEMP.	3 M	50 / 70	E27	OSRAM - VIALOX NAV-T 70 4Y	
83-4549-AX-37	□	3 M	70	E27	OSRAM - VIALOX NAV-T 70 4Y	
83-4550-AX-37	□ 2N	3 M	50 / 70	E27	OSRAM - VIALOX NAV-T 70 4Y	
83-4551-AX-37	□ 2N TEMP.	3 M	50 / 70	E27	OSRAM - VIALOX NAV-T 70 4Y OSRAM - HCI-TT 70/830 WDL PB	
83-4494-AX-37	⊕	5 M	35	G12	OSRAM - HIC-T 35/830 WDL PB	
83-4495-AX-37	⊕	5 M	70	G12	OSRAM - HIC-T 70/830 WDL PB	
83-4496-AX-37	⊕	5 M	100	G12	OSRAM - HIC-T 100/830 WDL PB	
83-4497-AX-37	⊕	5 M	150	G12	OSRAM - HIC-T 150/830 WDL PB	
83-4498-AX-37	□	5 M	35	G12	OSRAM - HIC-T 35/830 WDL PB	
83-4499-AX-37	□	5 M	70	G12	OSRAM - HIC-T 70/830 WDL PB	
83-4500-AX-37	□	5 M	100	G12	OSRAM - HIC-T 100/830 WDL PB	
83-4501-AX-37	□	5 M	150	G12	OSRAM - HIC-T 150/830 WDL PB	
83-4502-AX-37	⊕	5 M	70	E27	OSRAM - VIALOX NAV-T 70 4Y OSRAM - HCI-TT 70/830 WDL PB	
83-4503-AX-37	⊕	5 M	100	E40	OSRAM - VIALOX NAV-T 100 OSRAM - HCI-TT 100/830 WDL PB	
83-4504-AX-37	⊕	5 M	150	E40	OSRAM - VIALOX NAV-T 150 4Y OSRAM - HCI-TT 150/830 WDL PB	
83-4505-AX-37	⊕ 2N	5 M	70	E27	OSRAM - VIALOX NAV-T 70 4Y	
83-4506-AX-37	⊕ 2N	5 M	100	E40	OSRAM - VIALOX NAV-T 100	
83-4507-AX-37	⊕ 2N	5 M	150	E40	OSRAM - VIALOX NAV-T 150 4Y	
83-4508-AX-37	⊕ 2N TEMP.	5 M	70	E27	OSRAM - VIALOX NAV-T 70 4Y	
83-4509-AX-37	⊕ 2N TEMP.	5 M	100	E40	OSRAM - VIALOX NAV-T 100	
83-4510-AX-37	⊕ 2N TEMP.	5 M	150	E40	OSRAM - VIALOX NAV-T 150 4Y	
83-4511-AX-37	□	5 M	70	E27	OSRAM - VIALOX NAV-T 70 4Y OSRAM - HCI-TT 70/830 WDL PB	
83-4512-AX-37	□	5 M	100	E40	OSRAM - VIALOX NAV-T 100 OSRAM - HCI-TT 100/830 WDL PB	
83-4513-AX-37	□	5 M	150	E40	OSRAM - VIALOX NAV-T 150 4Y OSRAM - HCI-TT 150/830 WDL PB	
83-4514-AX-37	□ 2N	5 M	70	E27	OSRAM - VIALOX NAV-T 70 4Y	
83-4515-AX-37	□ 2N	5 M	100	E40	OSRAM - VIALOX NAV-T 100	
83-4516-AX-37	□ 2N	5 M	150	E40	OSRAM - VIALOX NAV-T 150 4Y	
83-4517-AX-37	□ 2N TEMP.	5 M	70	E27	OSRAM - VIALOX NAV-T 70 4Y	
83-4518-AX-37	□ 2N TEMP.	5 M	100	E40	OSRAM - VIALOX NAV-T 100	
83-4519-AX-37	□ 2N TEMP.	5 M	150	E40	OSRAM - VIALOX NAV-T 150 4Y	

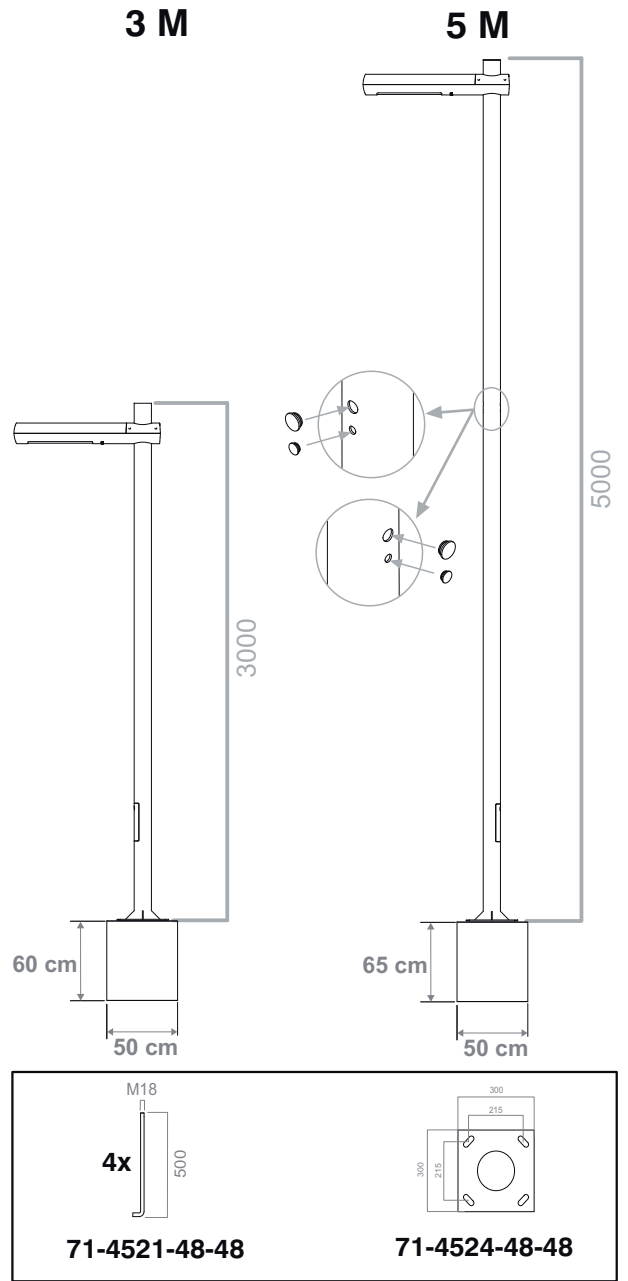

- Todos los productos están fabricados siguiendo las normas de seguridad y electromagnetismo de Europa: EN 60598-1:2004, EN 60598-2-3:2003, EN 55015:2006, EN 61000-3-2:2006, EN61000-3-3:1995, EN 61547 y marcado CE.  
- All products are manufactured according to the European safety norms and electromagnetic standards: EN 60598-1:2004, EN 60598-2-3:2003, EN 55015:2006, EN 61000-3-2:2006, EN61000-3-3:1995, EN 61547 and CE mark.

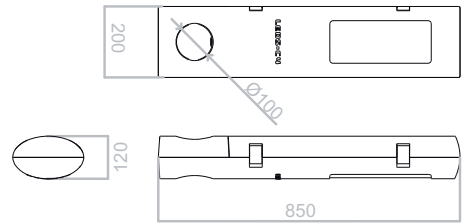
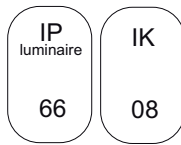

#### DERECHOS DE GARANTÍA

El fabricante LEDS-C4, S.A. garantiza el correcto funcionamiento del equipo y posibles reparaciones o suministro de recambios del modelo debidos a defectos de fabricación durante 2 años desde la fecha de entrega, pero no puede responsabilizarse de daños y/o perjuicios causados por un mal empleo del mismo. Para cualquier reclamación, se deberá adjuntar a esta garantía el ticket de compra. La empresa se compromete a la reparación total gratuita de los vicios o defectos originados y de los daños y perjuicios directamente ocasionados por ellos. Asimismo, si la reparación no es satisfactoria y el objeto no alcanza las condiciones óptimas para cumplir el uso al que está destinado, el titular de la garantía tendrá derecho a la sustitución del objeto adquirido por otro de idénticas características o la devolución del precio pagado.

#### WARRANTY RIGHTS

LEDS-C4, S.A. guarantee the correct operation of this equipment, repairs or spare parts of the model due to defects in workmanship for 2 years as of the delivery date but accept no responsibility for damages caused through improper use. Claims must be accompanied by proof of purchase.  
The company agrees to repair any defect or malfunction found in the item and any damages said defect or malfunction might cause directly. Should the repair fail to satisfy the customer and/or the object fail to present the optimum condition for the use for which it is intended, the guarantee holder will be entitled to the replacement of the acquired item with another of identical characteristics or a complete refund of the purchase price.  
Composition: Finishes: plating and/or Epoxy paints and compounds of noble materials. Structure: brass, steel and cast iron. Other components: alabaster, crystal, fabric shades, wood and leather.

⊕ Luminaire en que la protección contra los choques eléctricos no recae exclusivamente sobre el aislamiento principal, sino que comporta una medida de seguridad suplementaria bajo la forma de medios de conexión de las partes conductoras accesibles, a un conductor de protección puesto a tierra, formando parte del cableado fijo de la instalación, de tal manera que las partes conductoras accesibles no puedan llegar a ser peligrosas en caso de defecto del aislamiento principal. / Luminaire in which protection against electric shock does not rely on basic insulation only, but which includes an additional safety precaution in such a way that means are provided for the connection of accessible conductive parts to the protective (earthing) conductor in the fixed wiring of the installation in such a way that accessible conductive parts can not become live in the event of a failure of the basic insulation.

□ Luminaire en que la protección contra los choques eléctricos no recae exclusivamente sobre el aislamiento principal, sino que comprende medidas de seguridad suplementarias, tales como el doble aislamiento o el aislamiento reforzado. Estas medidas no comprenden medios de puesta a tierra de protección y no dependen de las condiciones de instalación. / Luminaire in which protection against electric shock does not rely on basic insulation only, but in which additional safety precautions such as double insulation or reinforced insulation are provided, there being no provision for protective earthing or reliance upon installation conditions.

⊕---m Distancia mínima de los objetos iluminados (metros). / Minimum distance from lighted objects (meters).

⚠ Sustituir cualquier pantalla de protección con fisuras. / Replace any cracked protective shield.

⚠ Luminares previstas para el montaje directo sobre superficies normalmente inflamables. / Luminaires suitable for direct mounting on normally flammable surfaces.

⚠ Luminares para lámparas de vapor de sodio a alta presión que exigen un arrancador exterior (a la lámpara). / Luminaires for use with high pressure sodium lamps that require an external ignitor (to the lamp).

IP Sistema de codificación para indicar los grados de protección proporcionados por la envolvente contra el acceso a las partes peligrosas, contra la penetración de agua y contra la penetración de cuerpos sólidos extraños. / Coding system to indicate the degree of protection provided by the enclosure against access to hazardous parts, against the penetration of water and the penetration of solid foreign bodies.

#### INSTALACIÓN Y MANTENIMIENTO / INSTALLATION AND MAINTENANCE

- Luminaire solo apta para uso exterior. / Luminaire suitable for external use only.  
- El cable manguera para la conexión a red en el interior de la luminaria no debe tocar ni la reactancia ni el reflector. / The electrical wire for the connection inside the luminaire should not touch or the ballast or reflector.  
- Para mantener el rendimiento óptimo de la luminaria, se requiere la limpieza periódica del vidrio, su frecuencia dependerá de las condiciones ambientales de la instalación. / To maintain optimum performance of the luminaire will require periodic cleaning of the glass, its frequency will depend on the environmental conditions of the installation.  
- Se debe desconectar la luminaria del suministro eléctrico antes de proceder al cambio de la lámpara, manipular o realizar cualquier tipo de mantenimiento. Existen altas tensiones dentro de la misma y todas las precauciones tomadas usualmente en la manipulación de equipos de alta tensión deben ser adoptadas igualmente en las operaciones de cambio de lámpara o cualquier otra manipulación. / The luminaire must be disconnected from the power supply before proceeding to change the lamp, manipulate or perform any maintenance. There are high voltages inside the same and usually taken every precaution in handling high voltage equipment must be taken also in the exchange of light or any other manipulation.  
- Este aparato cumple con las Directivas del Nuevo Reglamento Electrotécnico de Baja tensión y Compatibilidad Electromagnética, En caso de no llevar equipos eléctricos, el aparato no estará sometido a la Directiva de Compatibilidad Electromagnética. / This device complies with the directives of the New Electro Regulation Low Voltage and Electromagnetic Compatibility, if not to electrical equipment, the device shall not be subject to the Electromagnetic Compatibility Directive.