

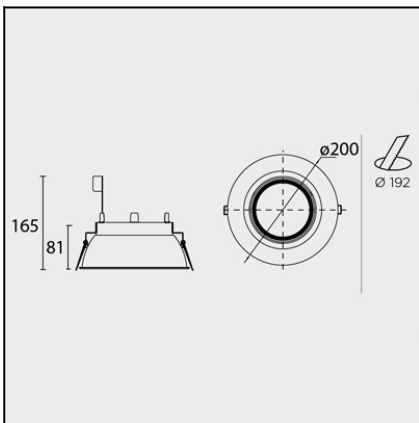

The photograph may not match the reference exactly. Please read the product description to identify the finish.



### DESCRIPTION

Round downlight for flush mounting with high visual comfort to avoid glare problems. Body produced in stamped steel plate and mounting springs made of hardened stainless steel. Fixed and rotating models tilting up to 40° vertically. Suitable for halogen lamps, discharge lamps and LED lamps. With the option of incorporating colour filters.

### TECHNICAL CHARACTERISTICS

Type:	Downlight
Adjustable	±20° on the horizontal axis.
IP Protection degrees:	IP23
Lampholder:	1 x G53
Power (W):	G53 100
Total power consumption (W):	100
Voltage / Frequency:	12V/50Hz
Warranty (Years):	2
Units per box:	12
Net Weight (Kg):	0.52
EAN:	8435111081006,00

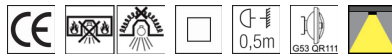

### MATERIALS / FINISHES

**Structure material:** Steel  
**Structure finish:** White

### GEAR

Necessary equipment not included. For more information check website / catalogs / sales organization.

QR-111 G53 100W 45°

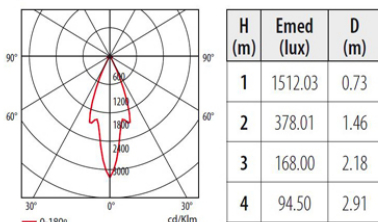

η=100 %

Download photometric file .ldt / .ies

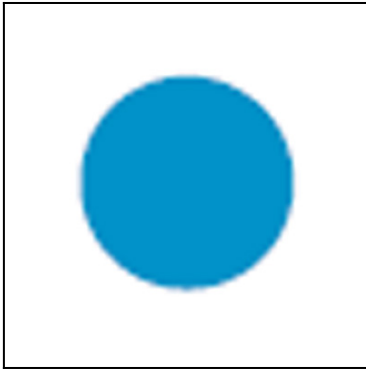
**ACT-9131-11-00**Colour filter for QR111 lamp**Diffuser material:**

Glass

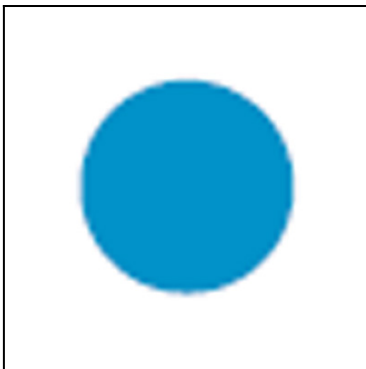
**ACT-9131-08-00**Colour filter for QR111 lamp**Diffuser material:**

Glass

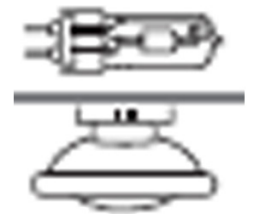
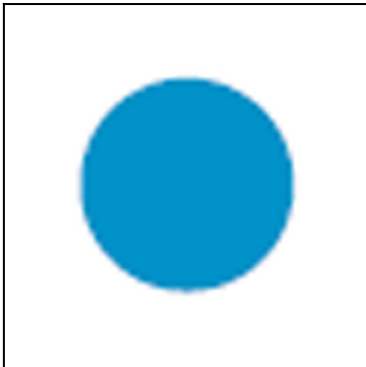
**ACT-9131-25-00**Colour filter for QR111 lamp**Diffuser material:**

Glass

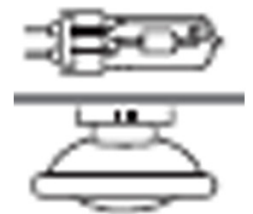
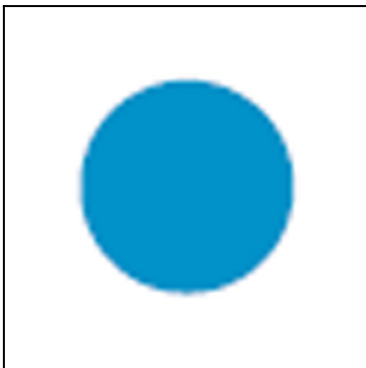
**ACT-9131-24-00**Colour filter for QR111 lamp**Diffuser material:**

Glass



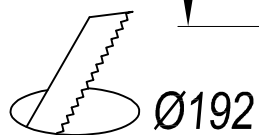
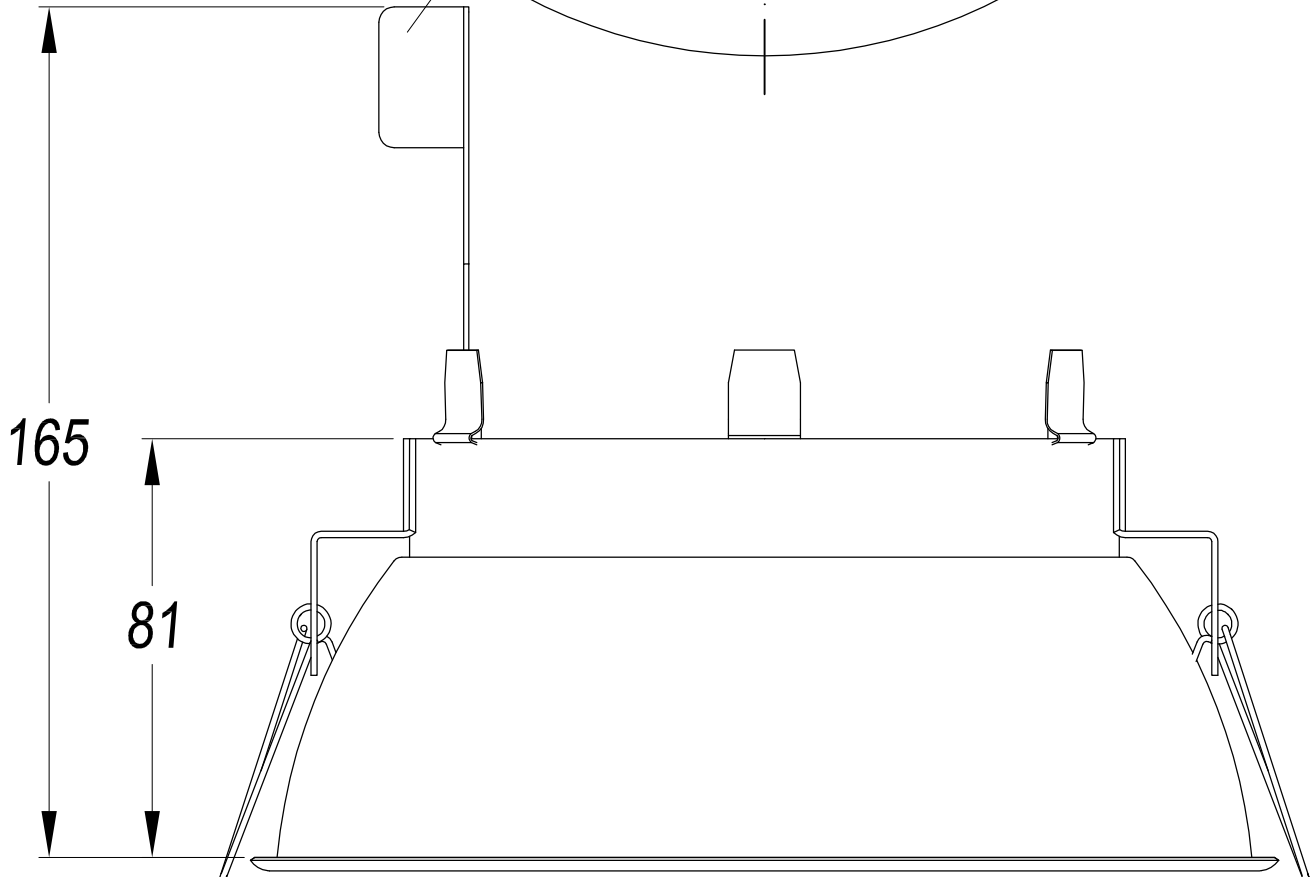
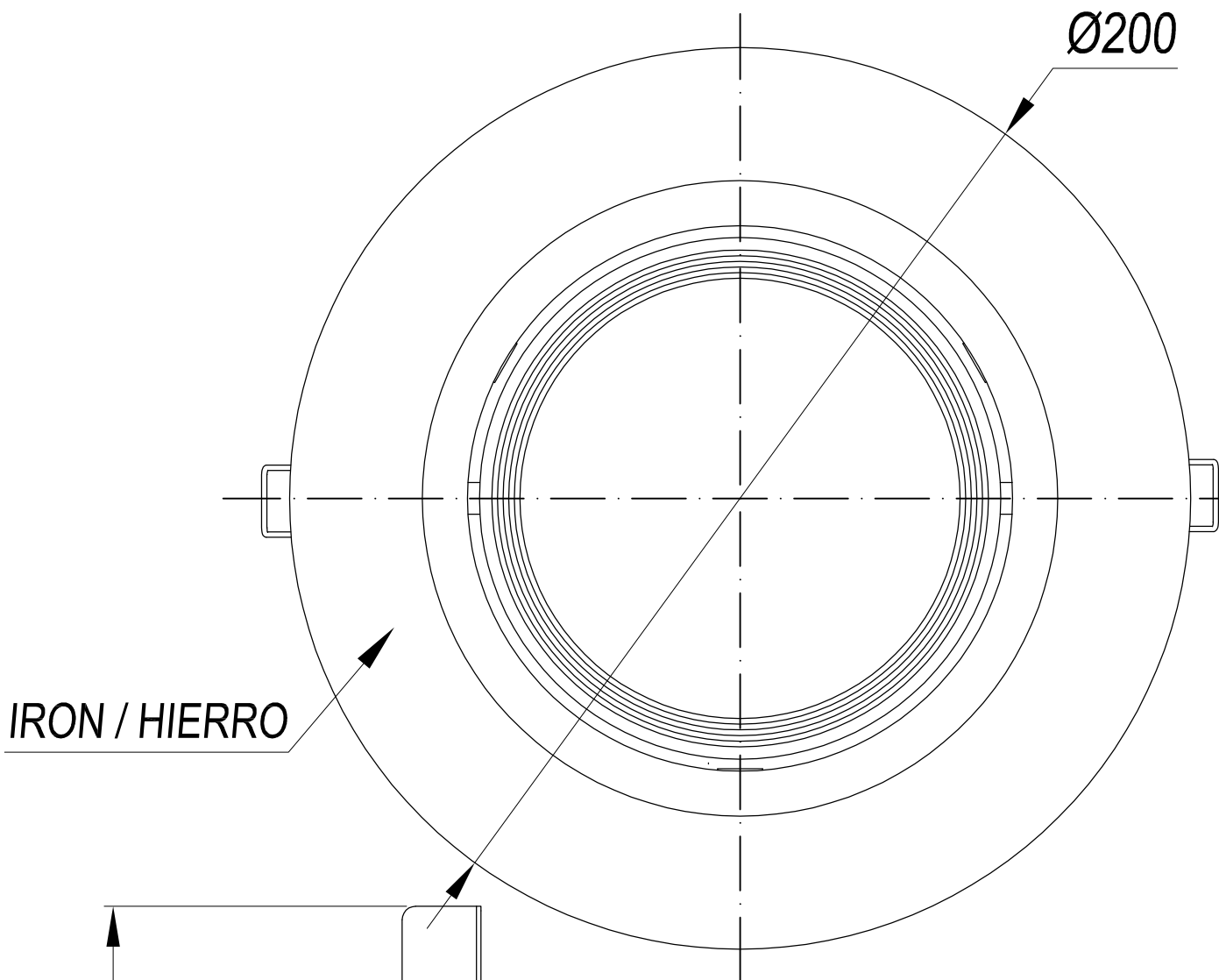

REF.	∅	LAMP	SOCKET
DN-1602-14-00	Ø192	QR111 12V Max.100W	G53
DN-1603-14-00	Ø192	CDM - R111 Max.70W	Gx8,5
DN-1651-14-00	Ø192	AR-111 Max.50W	Gu10

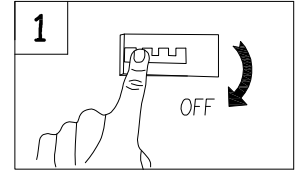

**2**

**QR-111**

**3**

Electronic Transformer  
Transformador electrónico

230 / 240V  
50....60Hz

**2**

**CDM-R111**

**3**

Electronic equipment  
Equipo electrónico

230 / 240V  
50....60Hz

**2**

**AR-111**

**3**

